

artu

2022 COLLECTIONS

Artu brand is a tight-knit team of professionals, designers and engineers thoughtfully weaving in tandem refined, distinct and intelligent furniture designs.

Artu prides itself on offering a wide range of modern furniture to create working and living spaces for HoReCa segment, as well as offices and homes that are equal part organization and inspiration.

Artu is fully committed to deliver exceptional design, manufacturing excellence and performance that bridges people and technology.

contacts

info@artu.works

English/Spanish +48 451017929

German/Russian +49 17658085902

Polish +48 882032511

Finnish +358 4578356677

Moss

overview p. 106

Soft, flowing, tactile forms of the new Moss collection are inspired by moss that embraces the surface of stone or wood. There are no sharp corners, every detail is conducive to comfort and coziness.

Wooden frame, soft upholstery,
various colours

by Pavel Vetrov



The Moss collection is available in three sizes from a single seat to a three-person sofa.



Wooden frame, soft upholstery,
various colours



Moss collection

Moss collection items can be produced with any upholstery regarding to customer wishes.



by Pavel Vetrov

overview p. 106



overview p. 107

When Sergey Lvov named his collection Tuttu Monteur (French for "Editor") he took inspiration from the core of an editor's business to refine the essence of the material and to convey the proper message. The Tuttu Monteur collection message is represented by streamlined, aesthetic, modern, ergonomic set of seatings.

Metal, upholstery,
various colours

by Levantin design

Tuttu Monteur



Tuttu collection

Smooth shapes form a clean silhouette, which is particularly well for modern interiors.



by Levantin design

overview p. 107



The Tuttu collection consists of an armchair and a sofa, which can be made in different colors.



The Levantin studio design approach can be described as **WOW** in your space.



Wox

overview p. 108-109

The design was created based on the silhouette of a running ox, which later affected the name (Wild Ox). In addition to the stylish and current design, these models can be stackable, and this significantly simplifies the conditions of storage and transportation.

Available in different colours.
Comes with wooden seat or
soft textile pad

by Pavel Vetrov



reddot award 2020
winner



The dining chair is available in two backrest options.



Wooden frame, various colours



Wox barstool can be produce in half bar version with requested seat height



Showroom Slotex / AB Kartun / Ivan Sorokin

by Pavel Vetrov



Wox metal took its design from the other products of the collection but was developed especially for places with very intense patency.



Metal, ashwood,
various colours



overview p. 109

The design of a new product in Wox family was based on Wox 2 chair, this model, we were trying to make a chair for home interiors especially.

Chairs are stackable and available in 2 colors, black and natural ash-tree.

by Pavel Vetrov

Wox flat



The main idea of Wox Flat is to provide a low cost and easy way of shipping to the customers.



by Pavel Vetrov



Katana

overview p. 110

The shapes and patterns in the Katana collection were inspired by traditional Japanese katana sword and kimono dress. These two unique seating options offer comfort and harmony with peaceful touch of Zen style to your space.

Ashwood base, metal frame,
upholstery

by Pavel Vetrov



Decorative elements with stitches
make up the handle of the katana
sword.



by Pavel Vetrov



Bar Berloga / Anastasia Zimatskaya / Anton Ivanov

Available in different stain and upholstery options.



by Pavel Vetrov

Modus

The metal bar stool Modus was designed by the Artu design bureau. While the creating of the Modus, we were inspired by our experience of working with establishments in the horeca segment.

Metal frame, upholstery



36

37

The main criteria in the design of the model were a universal design, which can be easily used in interiors of different styles, as well as special reliability and usability of the design.



overview p. 112

Lover is a new family of armchairs and bar stools by Spanish designer Pablo Regano, which consists of 3 pieces: an armchair, a bar stool, and a lounge chair. Pablo was inspired to create this collection by Colombian artist Fernando Botero's paintings and sculptures, namely his painting "Lovers".

Beechwood base, metal frame,
upholstery

by Pablo Regano

Lover



The disproportions of the objects in Batero's work were extrapolated into the design of the furniture, giving the items of the collection a pleasing curvaceous shape and a special softness and comfort in use.



by Pablo Regano



Collection consists of bar stool, arm chair and office armchair. All the items can be produced in various colors.



Beads

overview p. 113

Beads is a new table collection by Ukrainian designer Pavel Vetrov. The main idea was to use a simple small form of craft wooden beads in furniture. The natural pattern of ashwood supplements these items and makes them friendly and ecological.

Ashwood, metal

by Pavel Vetrov



The modern Scandinavian design of these tables is well suitable for contemporary interiors of restaurants, offices as well as homes. The base of the tables is made from solid wood and the countertop is touched up with a natural plywood-veneer.

Ashwood, metal



by Pavel Vetrov

Porto

The Porto workie table was developed by the designer Pavel Vetrov and the Artu design bureau. The visual inspiration for the creation of the table was the picturesque bridges of the Portuguese city, and the ergonomic ones were calculated based on the characteristics of the modern lifestyle.

Porto is made from solid ashwood and available in 2 colors, natural and black.

by Pavel Vetrov



Porto collection

The table is designed specifically to make it comfortable to use a computer while sitting on a sofa or in a lounge chair.



by Pavel Vetrov

overview p. 114



Lasso coat stand is a new look at the design and ergonomics of ordinary things. Due to the large round part, the usable storage area is increased several times, while the amount of space occupied is practically the same as the usual models of hangers

Material: metal

by Pavel Vetrov

Lasso



In addition to functionality, Lasso has an original shape and will be a well-designed item for modern minimalist interiors.



Coat stand Lasso can be made in any color according to the RAL palette.

by Pavel Vetrov

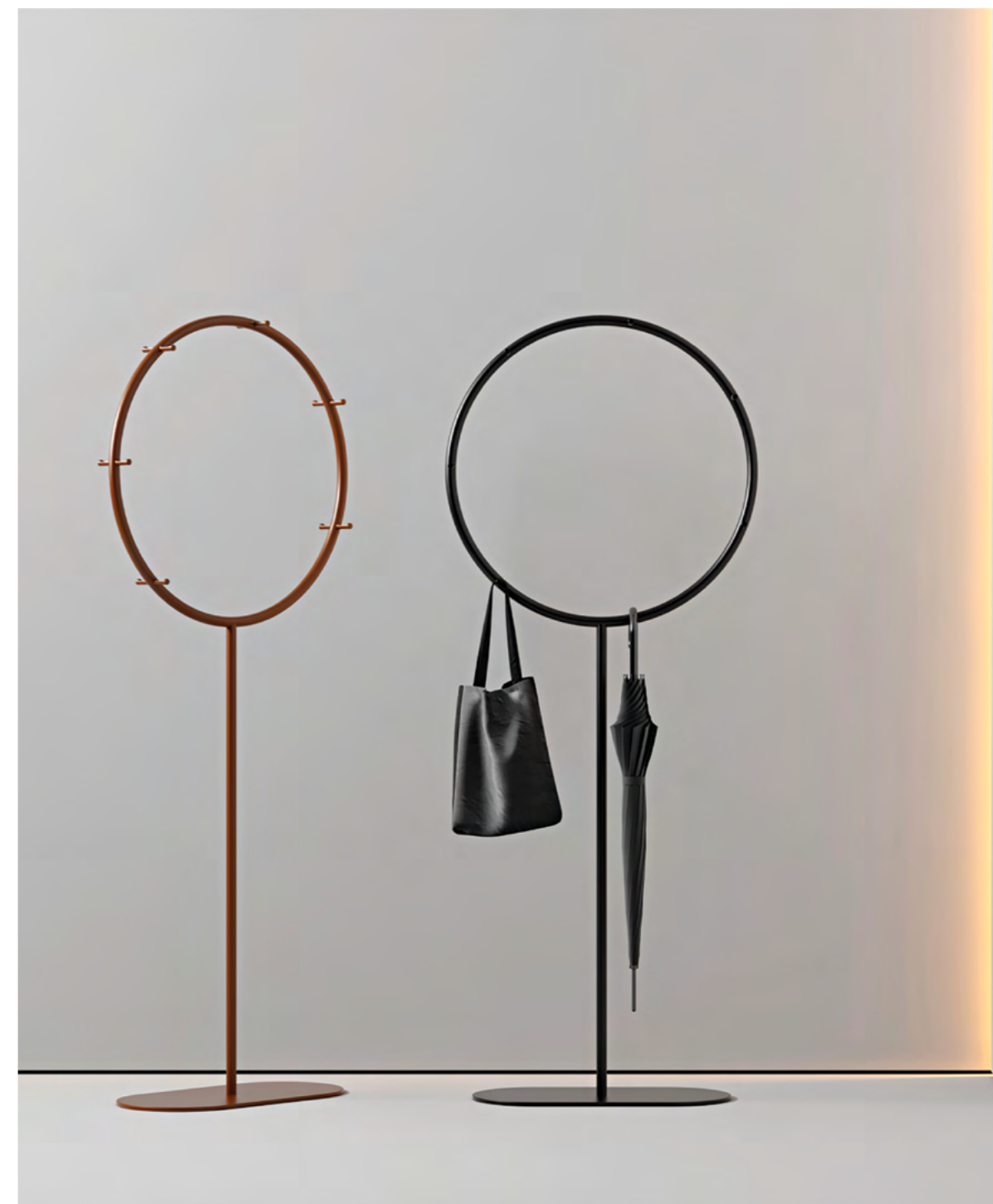

overview p. 116

Collection of metal chairs for the outdoors with the sophistication of an indoor chair. Le Tube chairs are perfect fit for street cafes and terraces but also can be placed in a living area or for some added color.

Materials: metal pipe, metal rod

by Figuron

Le Tube



Le Tube collection

Elegant and stackable Le Tube chair is available in any colors.



by Figuron

overview p. 116



Le Tube collection includes a classic metal frame chair, a bar stool and a bar chair with a back. All chairs are available in different colors.

Collection items can be additionally equipped with a soft seat



overview p. 117

Metal tables Lega were created as an addition to the Le Tube collection for public spaces and outdoor areas.

Metal, various RAL colors

by Figuron

Lega



Tables with a central Lega foundation can be done with two different bases, with square or round tops in two different sizes.

Lega tables are designed for outdoor use and are highly resistant to water and sun



Duran

The main idea behind the creation of the chair was the desire to combine the current trends in the design loft and mid-century in one product. At the same time, a special attention was paid to the quality of parts and materials.

Metal frame, oak veneer
plywood

by Figuron



The shapes and ergonomics of Duran were designed in such a way that the chair can become not only a comfortable seating position in the areas, but also a visual dominance in the interior.



At the request of the client, the Duran lounge chair can be made in various colors



Noook

The name Noook was formed from English word nook. Noook is the collection of privacy-encouraging office furniture intended to provide a creative solution that allows businesses to maintain popular open space design while respecting people's need for occasional privacy or closeted intimate communication.



Noook collection consists of three items. Each of them can be made in three different sizes.



Contemporary design and good ergonomics either perfectly fit for offices or libraries or easily can be placed in a home as an interesting room divider.

Metal, upholstery,
various colors



by Milodamalo

Marco

Collection is suitable for different styles of interior due to its minimalistic design and well thought out ergonomics. The chairs base and legs are made of solid beech. Seat and backrest are based on metal frame with a soft upholstery.

Solid beech, metal frame,
upholstery

by Figuron



**Marco collection consists of
3 different chairs with a same
beechwood bases**



Solid beech, metal frame, soft upholstery, various colors

by Figuron



Hotel Tochka na karte / Rhizome group / Dima Tsyrenshchikov

Due to its robust design it's capable of supporting weight over 150 kg



by Figuron



Tomorrow / CHEF DESIGN / Nikita Teplitsky

overview p. 123

Marco Pleat is a new version of Marco armchairs that were designed by Alexander Zhukovsky (Figuron). We freed the forms and it became a little bit more cosy and surreal.

Materials: metal frame,
upholstery

by Figuron

Marco pleat



Marco pleat collection

These chairs are available
with 3 different bases & in any
color.



by Figuron

overview p. 123



Marco Metal

overview p. 124-125

Marco metal is a continuation of the collection of chairs and armchairs designed by Alexander Zhukovsky. Laconic design and well-thought-out ergonomics make Marco Metal versatile for interiors of different styles.



by Figuron

The frames of Marco metal chairs and armchairs are made of bent metal pipes. Each model can be equipped with one of three types of bases L1, L2 and L4.



Metallic frame, soft upholstery,
various colours

by Figuron



Marco office

Chairs and armchairs Marco office are based on the collection of similar dining furniture. While creating the office collection we were motivated by a desire to create a comfortable workplace that will harmoniously complement modern interiors.



92



93

Items from the Marco office collection are available for order in various upholstery options and can be equipped with four types of bases.



by Figuron

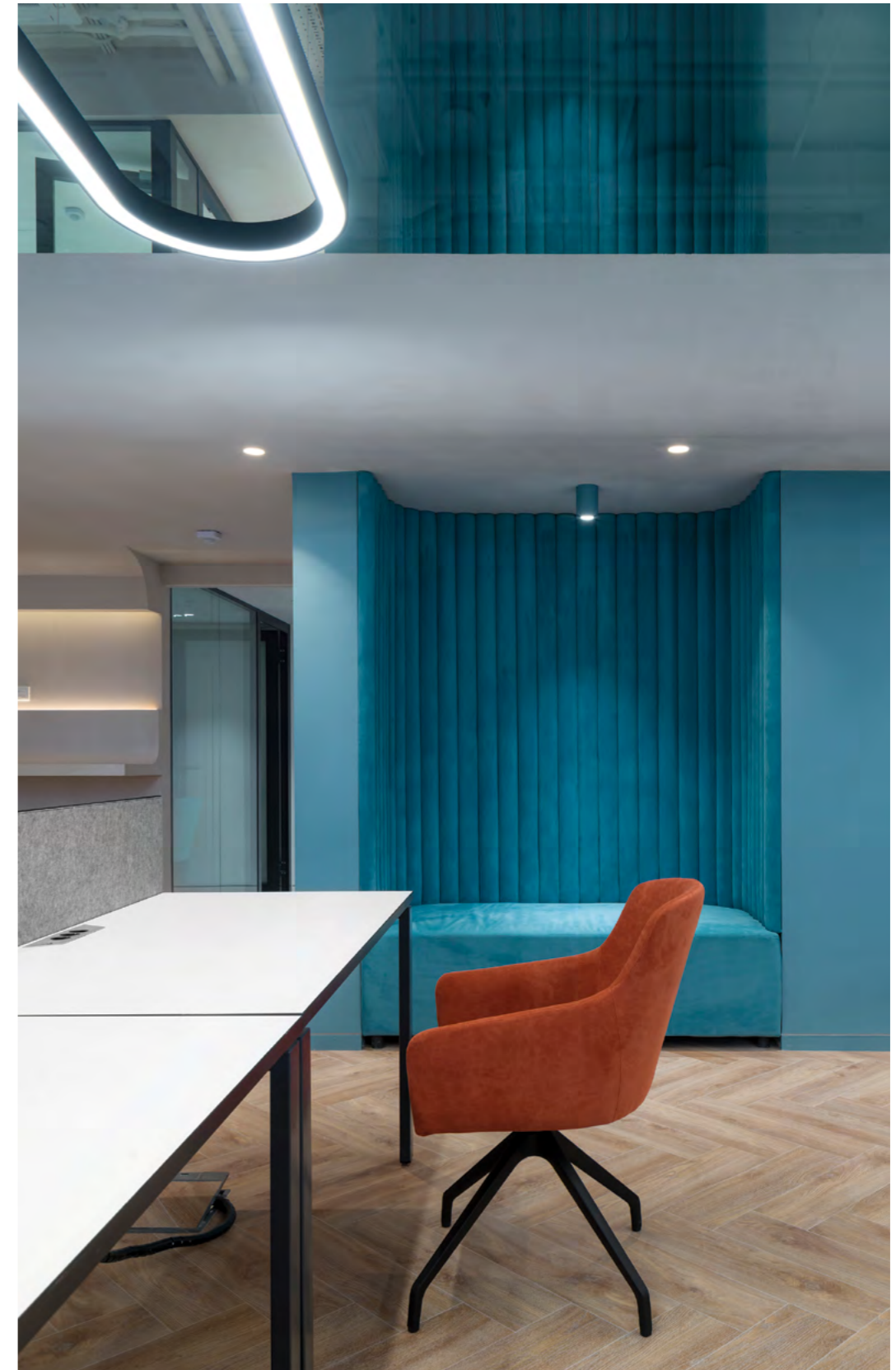

Space 1 / IND Architects

Due to its robust design
it's capable of supporting
weight over 150 kg.



Metal frame, upholstery,
4 kinds of office bases

by Figuron



Bank Office / KIDZ Design

Eclat

overview p. 128

Eclat is a collection, developed by Elena Khryascheva and inspired by the architecture of Milan and the spirit of Italian design. A balanced and refined style expresses a feeling of lightness and movement. The geometric base creates an object with a strong personality.

Metal, various RAL colours,
upholstery



by Elena Khryashcheva

Eclat collection

Eclat collection consists of bar stool, half bar stool and armchair.



by Elena Khryashcheva

overview p. 128

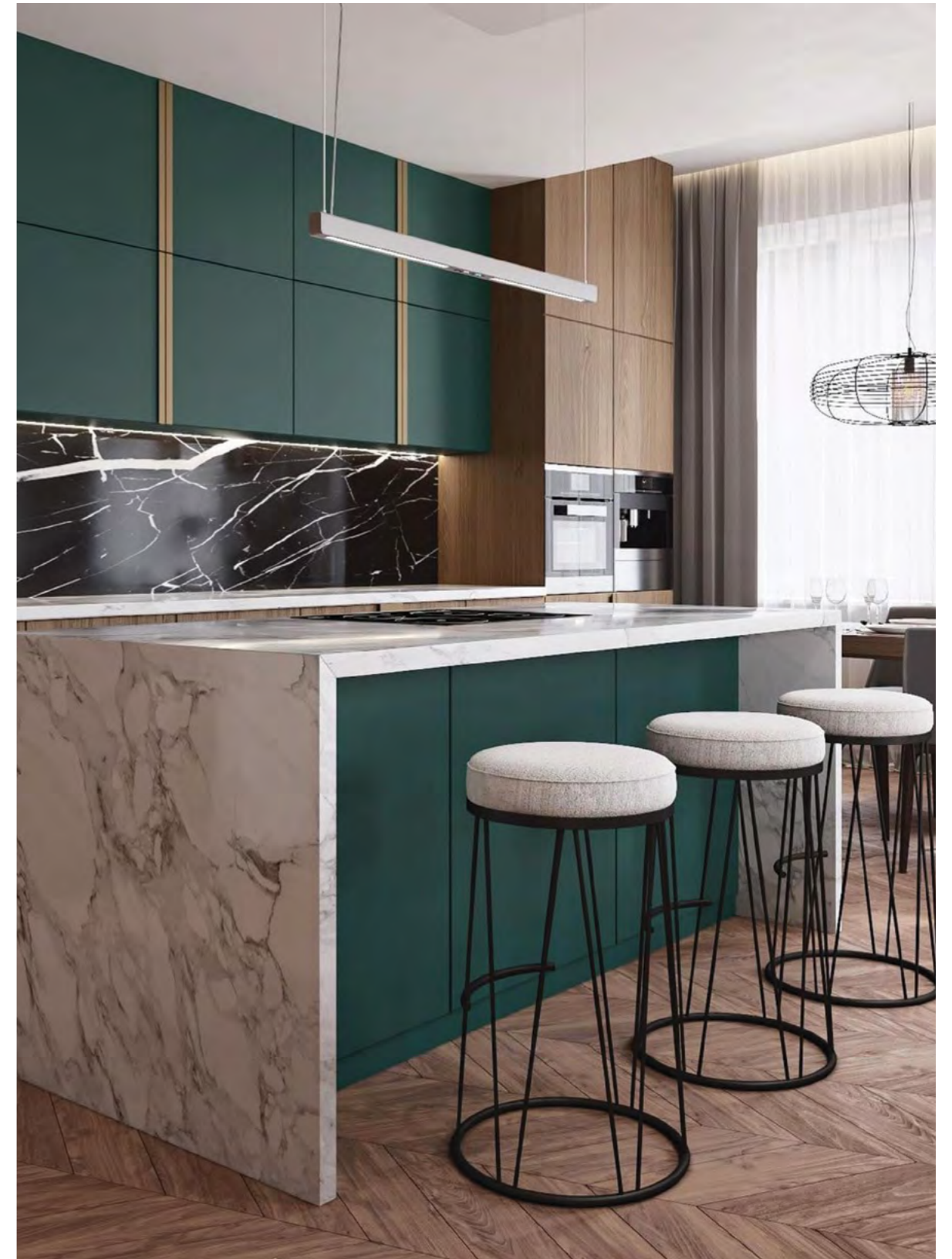

Apartment interior/ Elena Khryashcheva

Brent

Brent is primarily laconic, expressive and comfortable furniture. But apart from that, Brent Stool is something like a sarcastic symbol of modernity, it's the idea of expression interconnection of economics, politics and design in one small thing – a bar stool!

Ashwood, upholstery

by Figuron



102

103

Brent stool has its main conceptual color – black. But the whole Brent series can be painted in almost every color you wish.



it is also available to have Brent stool with wooden finishing.

by Figuron



Moss collection

collection p. 4-9

	Moss 1300	Moss 1800	Moss 2400
length	1300	1800	2400
depth	820	820	820
height	760	760	760
seating height	450	450	450
material	wood, upholstery	wood, upholstery	wood, upholstery



by Pavel Vetrov

Tuttu Monteur collection

collection p. 10-17

	Tuttu Armchair	Tuttu Sofa
length	676	1336
depth	840	840
height	779	779
seating height	510	510
material	metal, upholstery	metal, upholstery

The approach to design might be described as WOW in your space: "we implement the brave and cosmopolitan ideas, in demand with people who looks creatively at our world!".



by Levantin design

Wox collection

collection p. 18-29

	Wox	Wox 2	Wox Bar
length	536	536	508
depth	513	513	526
height	833	833	997
seating height	462	480	775
material	ashwood	ashwood	ashwood

	Wox Metal	Wox S	Wox 2S	Wox Bar S
length	536	536	536	508
depth	513	513	513	526
height	833	833	833	997
seating height	462	462	480	775
material	ashwood, upholstery	ashwood, upholstery	ashwood, upholstery	ashwood, upholstery

	Wox Flat
length	536
depth	513
height	833
seating height	480
material	ashwood



by Pavel Vetrov

Katana collection

collection p. 30-35

Modus collection

collection p. 36-39

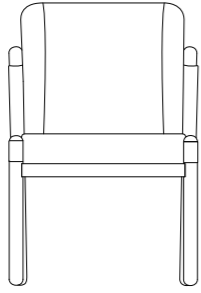
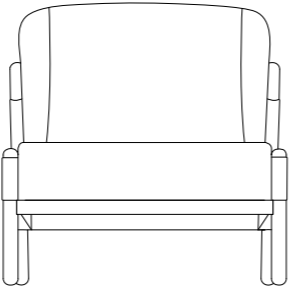
	Katana	Katana Lounge
		
length	572	800
depth	581	736
height	850	768
seating height	460	386
material	ashwood, upholstery	ashwood, upholstery

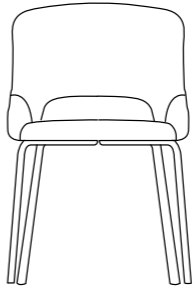
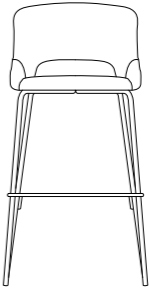
	Modus	Modus Bar
		
length	500	540
depth	547	515
height	748	1106
seating height	450	815
material	metal, upholstery	metal, upholstery

Ukrainian designer with 70 awards in design
he has amassed throughout his career



by Pavel Vetrov

lover collection

collection p. 40-45

Beads collection

collection p. 46-49

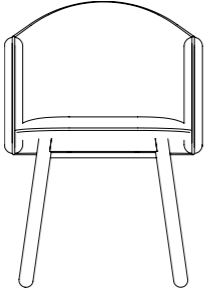
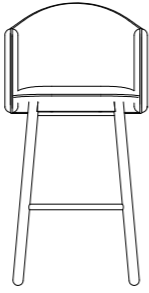
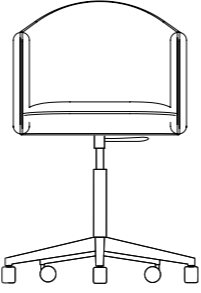
	Lover	Lover Bar	Love office
			
length	536	562	610
depth	593	593	610
height	811	1112	670-750
seating height	484	785	342 -422
material	beech, metal, upholstery	beech, metal, upholstery	office base, metal, upholstery

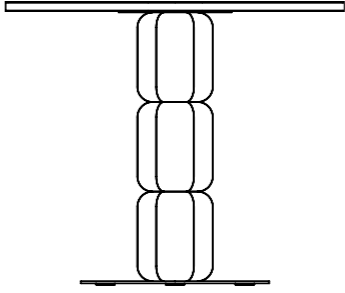
	Beads
	
length	900
depth	900
height	753
material	ashwood, metal

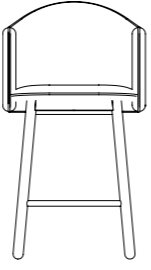
	Lover Half Bar
	
length	562
depth	593
height	1012
seating height	685
material	beech, metal, upholstery



by Pablo Regano

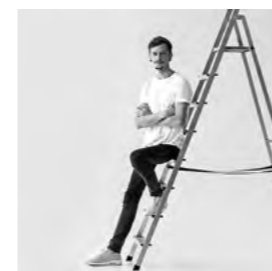

by Pavel Vetrov

Porto collection

collection p. 50-53

Lasso collection

collection p. 54-57

	Porto	Porto R
length	550	500
depth	350	500
height	550	550
material	ashwood	ashwood

	Lasso
length	720
depth	300
height	1800
material	metal



by Pavel Vetrov

Letube collection

collection p. 58-63

Lega collection

collection p. 64-67

length
depth
height
seating height
material

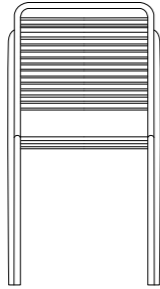
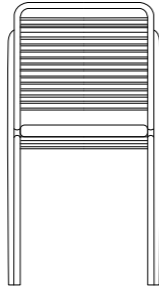
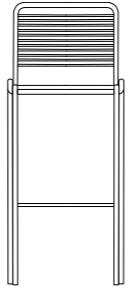
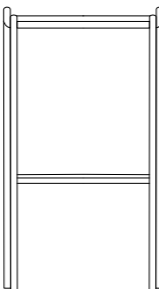
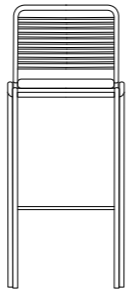
	Le Tube	Le Tube Soft	Le Tube Bar 1	Le Tube Bar 2	Le Tube Bar Soft
					
length	464	464	450	450	450
depth	552	552	460	460	460
height	842	842	1100	790	1100
seating height	447	477	790	790	820
material	metal	metal upholstered seat	metal	metal	metal upholstered seat

length
depth
height
material

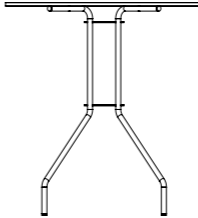
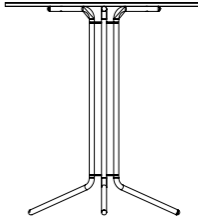
	Lega 4	Lega 7
		
length	600/700	600/700
depth	600/700	600/700
height	750	750
material	metal	metal



by Figuron

Duran collection

collection p. 68-71

Duran

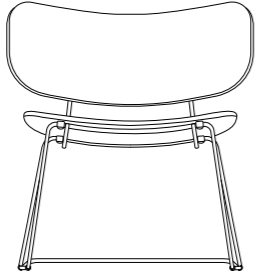

length 671
depth 662
height 728
seating height 405
material metal, plywood

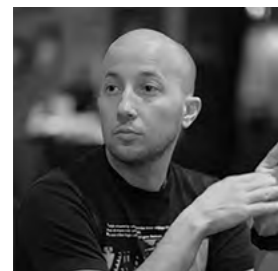

by Figuron

Noook collection

collection p. 72-77

Noook 1 1140

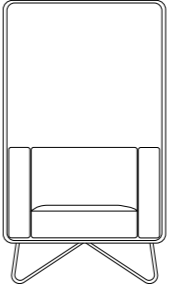

length 1140
depth 800
height 1686
seating height 460
material metal, upholstery

Noook 1 1600

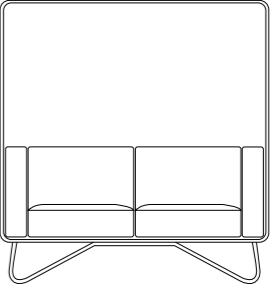

1600
800
1686
460
metal, upholstery

Noook 1 2200

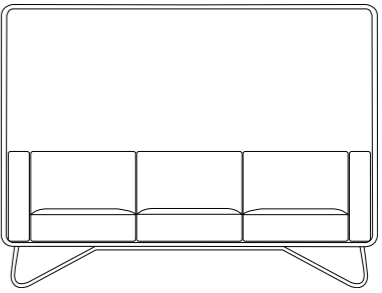

2200
800
1686
460
metal, upholstery



by Milodamalo

Nook collection

collection p. 72-77

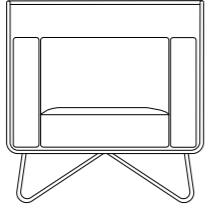
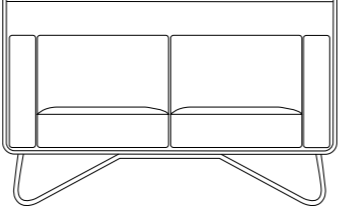
	Nook 2 1140	Nook 2 1600
		
length	1140	1600
depth	800	800
height	1046	1046
seating height	460	460
material	metal, upholstery	metal, upholstery

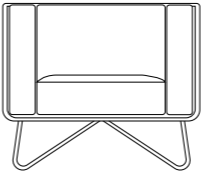
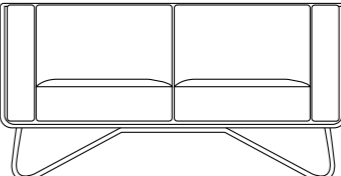
	Nook 3 1140	Nook 3 1600
		
length	1140	1600
depth	800	800
height	815	815
seating height	460	460
material	metal, upholstery	metal, upholstery

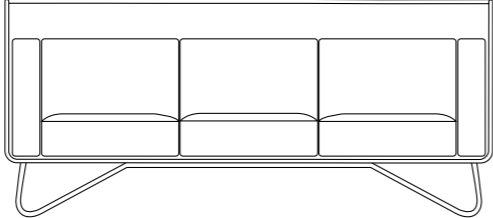
	Nook 2 2200
	
length	2200
depth	800
height	1046
seating height	460
material	metal, upholstery

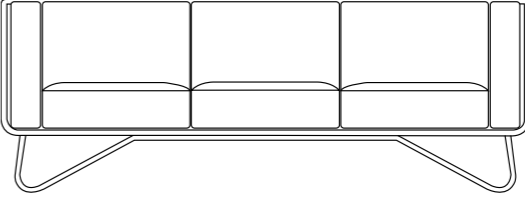
	Nook 3 2200
	
length	2200
depth	800
height	815
seating height	460
material	metal, upholstery



by Milodamalo

Marco collection

collection p. 78-83

Marco Pleat collection

collection p. 84-87

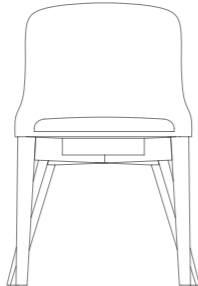
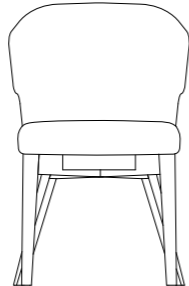
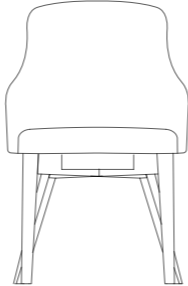
	Marco	Marco M2	Marco M3
			
length	520	530	560
depth	620	610	600
height	800	800	830
seating height	460	460	450
material	beech, metal, upholstery	beech, metal, upholstery	beech, metal, upholstery

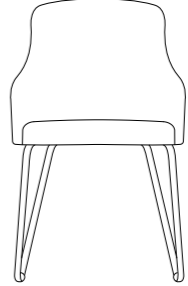
	Marco Pleat L1	Marco Pleat L2
		
length	560	560
depth	600	600
height	830	830
seating height	450	450
material	metal, upholstery	metal, upholstery

Establishing FIGURON art & design studio marked Alexander's shift of professional interests on creating of custom-made objects of arts and furniture.

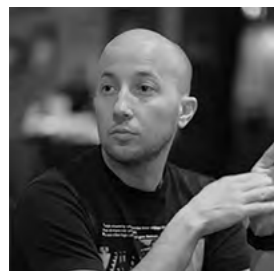

by Figuron

Marco Metal collection

collection p. 88-91

length
depth
height
seating height
material

	Marco L1	Marco M2 L1	Marco M3 L1
			
length	520	530	560
depth	620	600	620
height	800	800	830
seating height	460	460	460
material	metal, upholstery	metal, upholstery	metal, upholstery

	Marco L2	Marco L4	Marco M2 L2	Marco M2 L4
				
length	520	520	530	530
depth	620	620	600	600
height	800	800	800	800
seating height	460	460	460	460
material	metal, upholstery	metal, upholstery	metal, upholstery	metal, upholstery

	Marco M3 L2	Marco M3 L4
		
length	560	560
depth	620	620
height	830	830
seating height	460	460
material	metal, upholstery	metal, upholstery

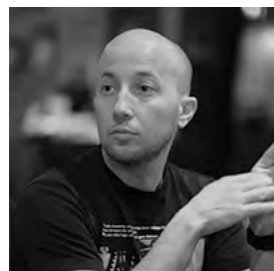



by Figuron

Marco Office collection

collection p. 92-97

length
depth
height
seating height
material

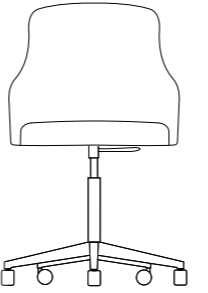
	Marco Office	Marco M2 Office	Marco M3 Office
			
length	630	630	645
depth	630	630	645
height	790-900	790-900	790-900
seating height	450-560	450-560	450-560
material	metal, upholstery office base	metal, upholstery office base	metal, upholstery office base

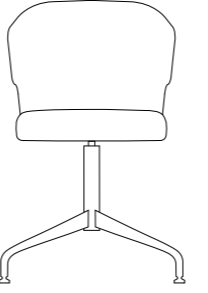
	Marco M2 Office RA
	
length	680
depth	680
height	510
seating height	880
material	metal, upholstery

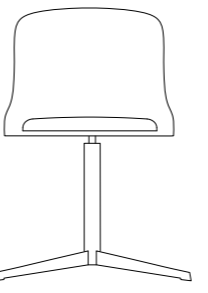
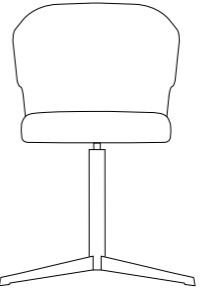
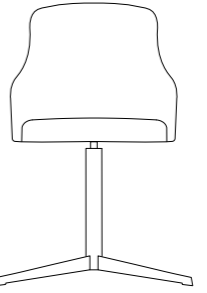
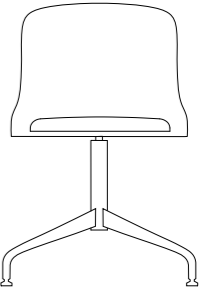
	Marco Office KPR	Marco M2 Office KPR	Marco M3 Office KPR	Marco Office RA
				
length	680	680	680	680
depth	680	680	680	680
height	820	830	830	870
seating height	460	460	460	510
material	metal, upholstery	metal, upholstery	metal, upholstery	metal, upholstery

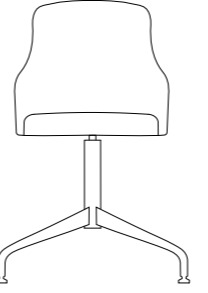
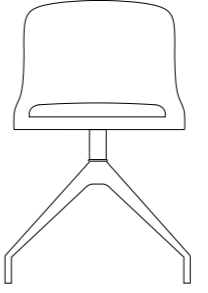
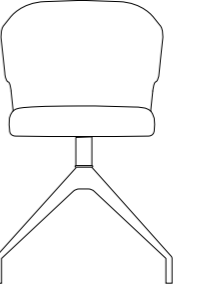
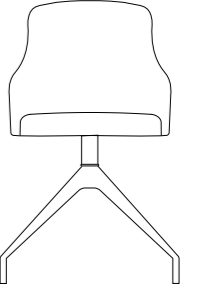
	Marco M3 Office RA	Marco Office Swiss	Marco M2 Office Swiss	Marco M3 Office Swiss
				
length	680	670	670	670
depth	680	670	670	670
height	920	820	830	860
seating height	510	460	460	460
material	metal, upholstery	plastic, upholstery	plastic, upholstery	plastic, upholstery

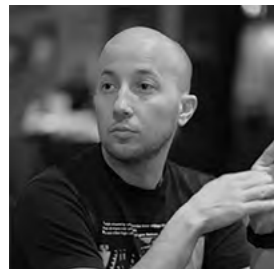

by Figuron

Eclat collection

collection p. 98-101

Eclat lounge

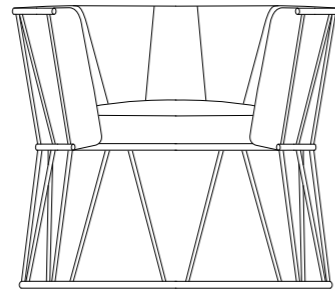

length	850
depth	684
height	700
seating height	470
material	metal, upholstery

Eclat Bar

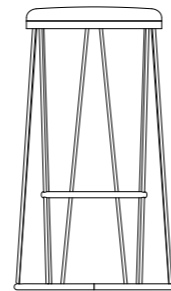

length	425
depth	425
height	790
seating height	790
material	metal, upholstery

Eclat Half Bar

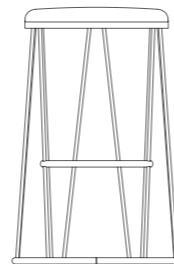

length	690
depth	455
height	690
seating height	690
material	metal, upholstery



by Elena Khryashcheva

Brent collection

collection p. 102-105

Brent

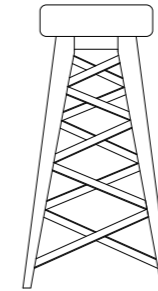

length	350
depth	350
height	830
seating height	830
material	ashwood

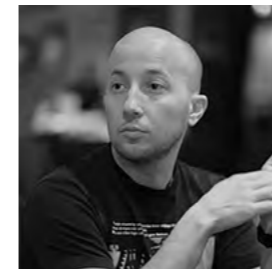

by Figuron

Pavel Vetrov

For almost a decade a Ukrainian designer Pavel Vetrov has worked in furniture and interior design commissioning projects for a number of renowned companies. Nowadays he runs his own-founded Pavek Vetrov firm specializing in custom furniture and design for residential and commercial spaces. Strict conciseness combined with elegant forms and proportions underscore the sharp style and maximum comfort and functionality of Pavel Vetrov furniture. Pavel has been featured in a number of renown publications, including Forbes, Elle, Vogue, Le Figaro . He has also won numerous awards and prizes to his credit, such as Red Dot Award, German Design Award, etc Pavel Vetrov is a regular participant at several design shows and exhibitions, like London Design Fair, Imm Cologne, Paris Design Week.

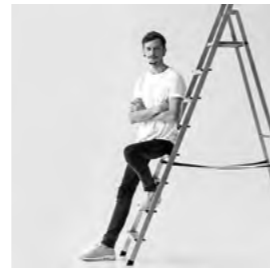

Figuron

Prior to opening his own practice, an industrial designer Alexander Zhukovsky worked for a number of companies related to automobile, medical equipment and home appliances businesses. Establishing FIGURON art & design studio marked Alexander's shift of professional interests on creating of custom-made objects of arts and furniture. The constant need for reinvention and endless aesthetic curiosity prods Alexander to experiment with various textures and materials while his industrial background is probably the key to why his furniture often has an extra dimension and many possibilities FIGURON furniture is aimed to make your life simpler, richer, more comfortable and more organized, providing more time to focus on the art of living.

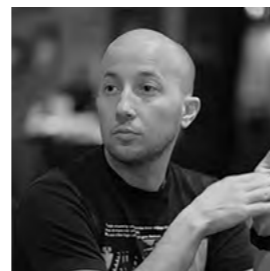

Elena Khryashcheva

Elena , who holds degrees from British School of Arts and Design and University of Hertfordshire (UK) is a founder of ELENIUM studio carrying out housing building and renovation , house refurbishing and interior design. With a background in architecture and extensive experience in interior design Elena offers to customers the furniture that combine immaculately detailed aesthetic with impeccable form and function that enhance people work, live and play in any contemporary space. Elena has earned a number of professional prizes and awards and is a permanent participant on professional Shows, Fairs and Exhibitions.

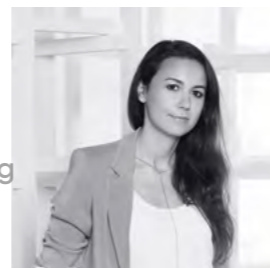

Levantin design

It was in 2012, when Sergey and Alexander Lvov brothers have shaken the professional community with their audacious experiments in furniture refurbishments. But for all the bravura moments they created, LEVANTIN DESIGN – multidisciplinary design studio they launched soon after the events, plys its craft with subtle discipline and uncompromising attention to technique and detail. The duo describe their design signature as “WOW in your space”. LEVANTIN DESIGN is utilising the utmost adventurous and revolutionary on the edge of disruptive and provocative design algorithms to create furniture for the same type of users – modern, cosmopolitan, open-minded life during individuals. LEVANTIN DESIGN has participated in a number of European Furniture Fairs and Exhibitions, such as a French Design Week hold in Paris, Barcelona Design week, etc.



Pablo Regano

Valencia (Spain) born product designer Pablo Regano draws his inspiration from his Mediterranean roots as is evident from his colourful, expressive and joyful design language. Pablo is passionate about creating beautiful and functional design products that are user-friendly and comfortable for work, gaming , and everything in-between.



Milodamalo

MILODAMALO is a multidisciplinary architecture, design and art studio, founded in 2009 by Maxim Nizov and Maria Surkova. MilodaMalo designation proves itself in the impeccable attention to detail, architectural forms and proportions of its diverse array of furniture and pieces of arts. MILODAMALO believe in skillfully balanced design enhancing beautifully balanced living environment. Maxim and Maria's ongoing dedication to intelligent and beautifully functional design has earned them many accolades over their professional career in Europe.



artu

The current price list is always available
by the following link



