

artu

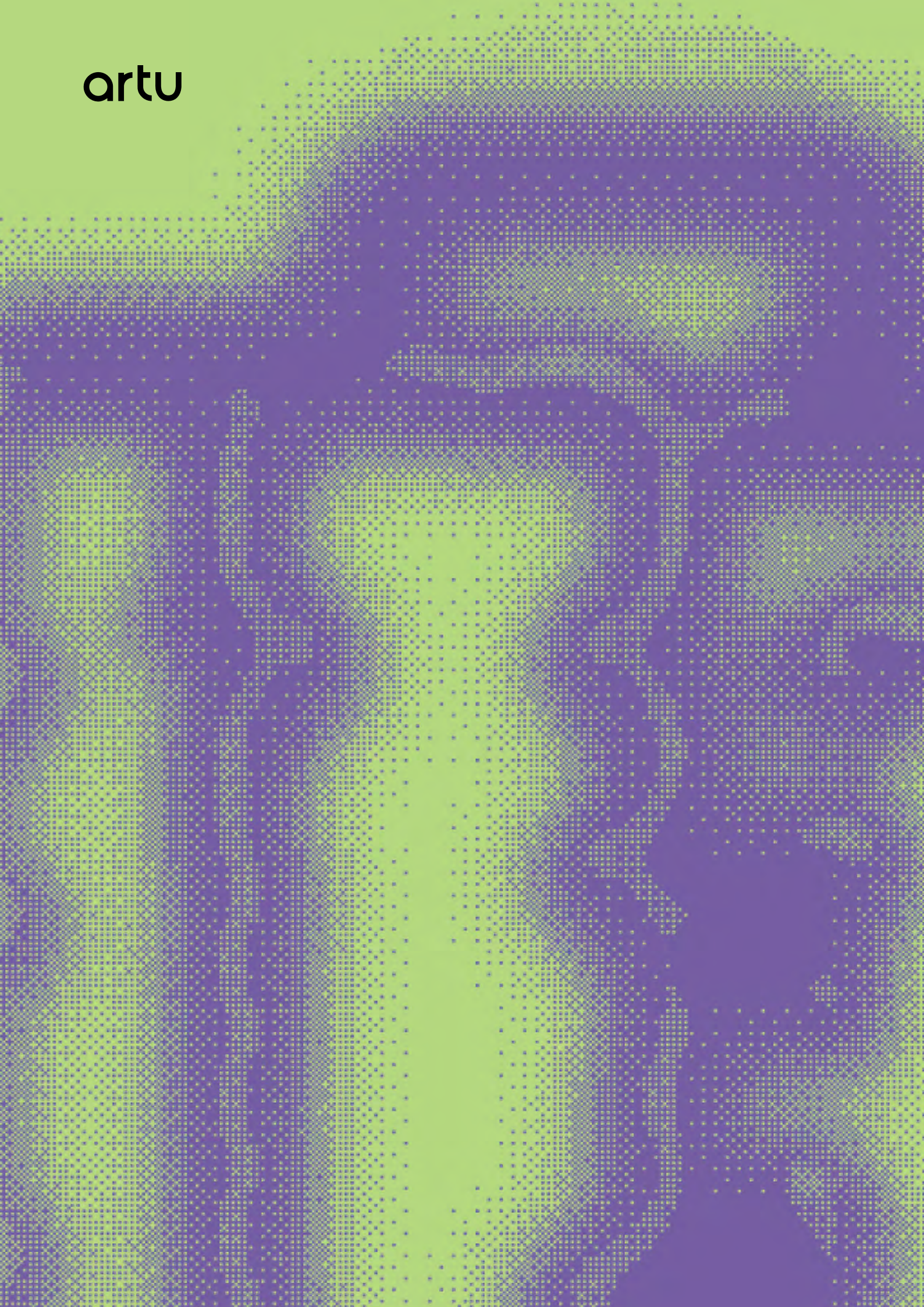

CONTENT

4	ABOUT
6	WOX
12	MOSS
18	EDDIE
24	LOVER
32	TAPTAP
38	JARA
42	NID
46	TUTU MONTEUR
52	KATANA
56	BEADS
62	PORTO
66	LASSO
70	CESTO
74	LYMMY
78	LETUBE
84	MARCO
88	MARCO PLEAT
92	MARCO METAL
96	MARCO OFFICE
102	TECH SPEC
116	DESIGNERS

The general Artu's concept is to create a modern and unique furniture for the HoReCa segment and offices.

Annually our engineers alongside the industrial designers create new models of chairs, tables and sofas and especially focus on ergonomic features of the product as well as esthetic.

Renowned for its unwavering dedication to quality craftsmanship and timeless design, Artu Furniture sets the standard for discerning enthusiasts of modern living.

WOX



The design was created based on the silhouette of a running ox, which later affected the name (Wild Ox).

In addition to the stylish and current design, these models can be stackable, and this significantly simplifies the conditions of storage and transportation.



The dining chair is available in two backrest options.





Wox barstool can be produce in half bar version with requested seat hight.

MOSS

Soft, flowing, tactile forms of the Moss collection are inspired by moss that embraces the surface of stone or wood. There are no sharp corners, every detail is conducive to comfort and coziness.



Moss collection is available in three sizes from a single seat to a three-person sofa.



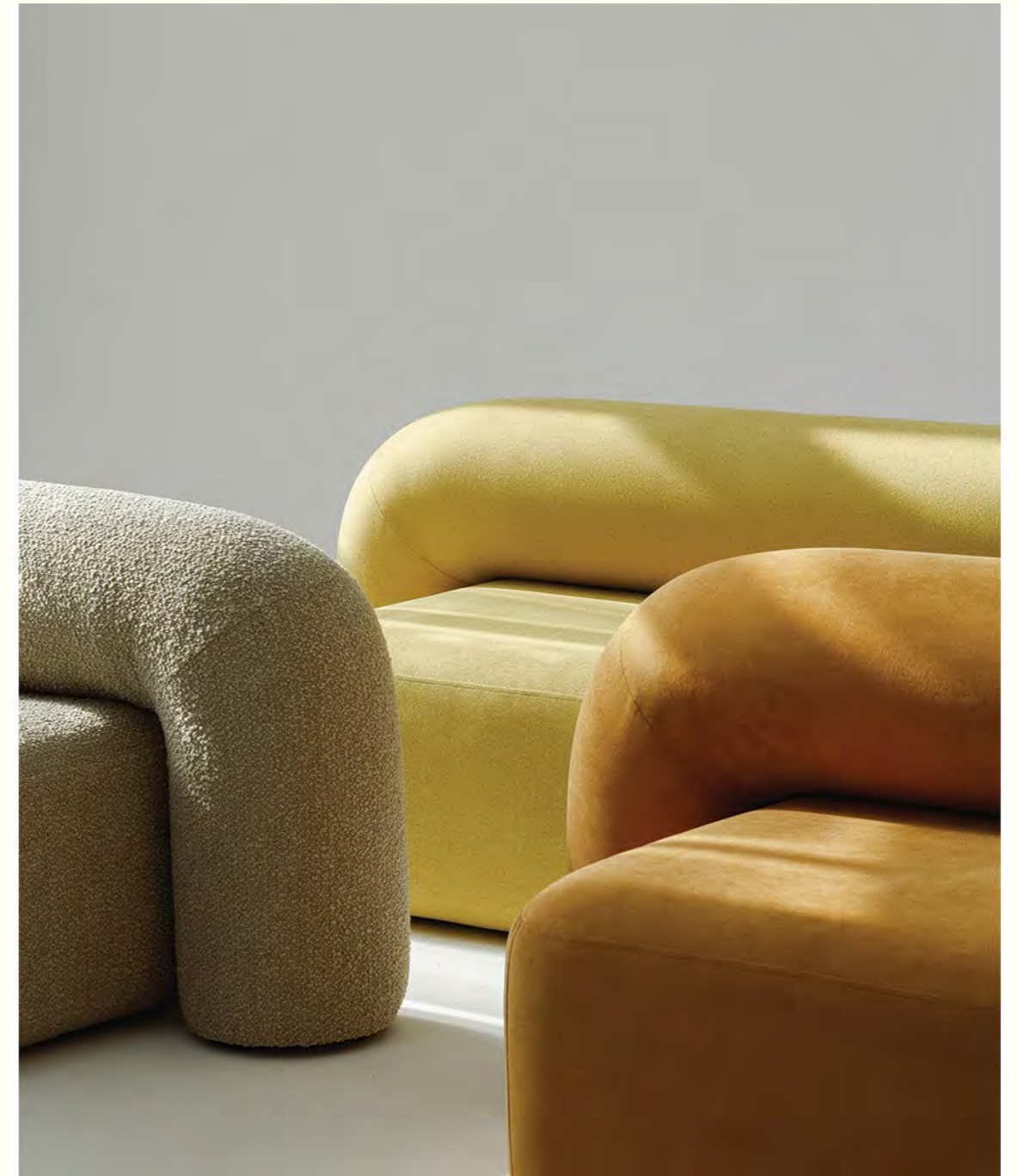

This sofa can be produced with any upholstery according to the customer's wishes.

Eddie



Eddie is a young and modern piece of wooden furniture designed for everyday use. Its stackability and comfortable seat make the chair concept adaptable to contemporary living environments – a true all-rounder for your home, as well as for offices and public spaces.





The Eddie chair is made of solid beech and moulded plywood parts, the surface can be optionally painted in various colors.

The Eddie bar stool is available for order in the half-bar version with the requested seat height.



Lover

Lover is a family of seatings by Spanish designer Pablo Regano. Pablo was inspired to create this collection by Colombian artist Fernando Botero's paintings and sculptures, namely his painting "Lovers". This armchair can be produced with any upholstery regarding to customer wishes.

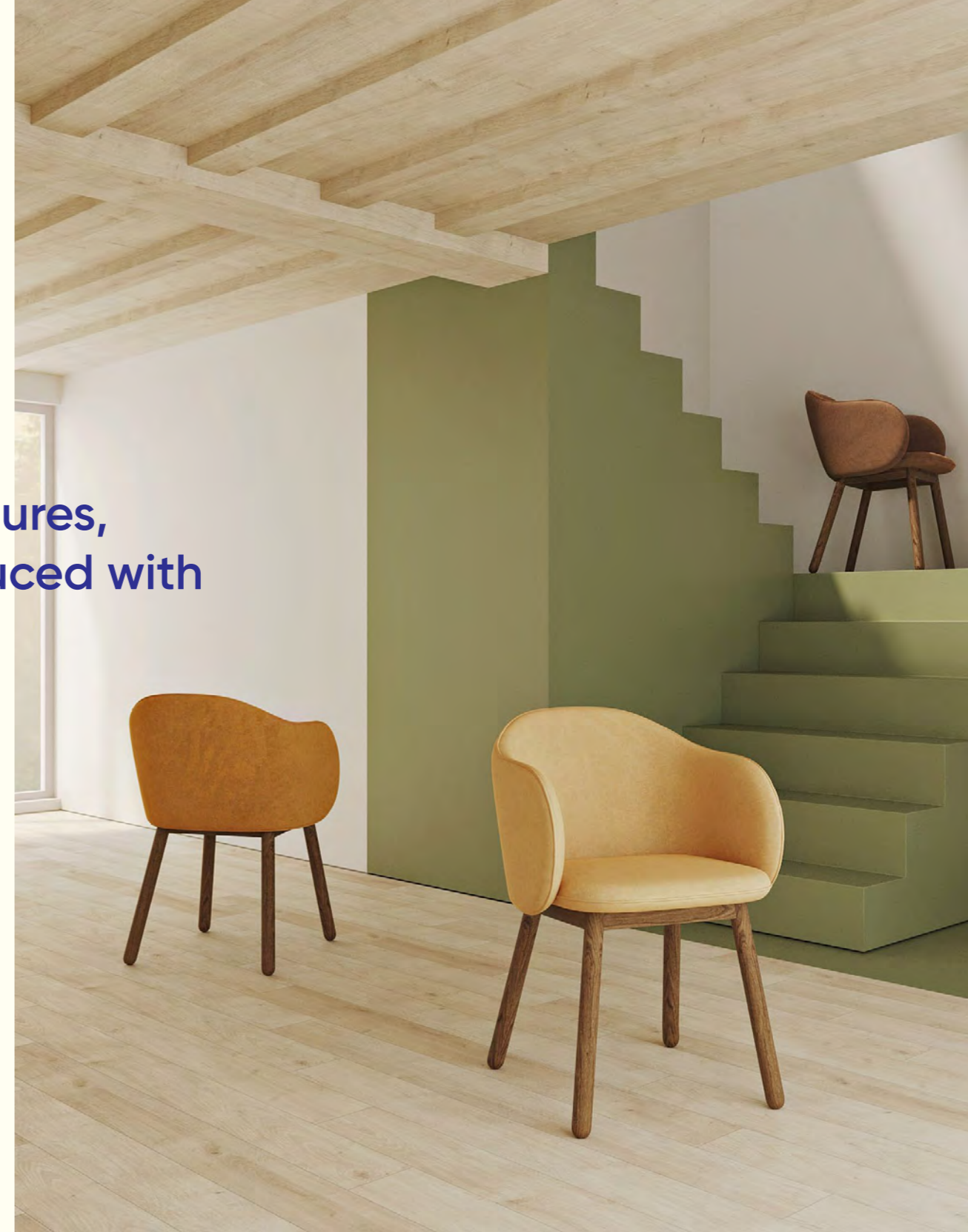



The collection consists of five pieces:
an armchair, a bar stool, an office chair,
a lounge chair, and a sofa.

Office chairs can be equipped with two different bases.



Wooden part colors and upholstery can be customized upon request.



TAPTAP



Taptap is a collection of visually striking yet practical pieces of furniture created by German designer Moritz Putzier. The idea is to create a compact piece of furniture that is versatile without taking up too much space. The design itself is characterised by finely crafted details and a playful use of geometric shapes and proportions that give each piece an unconventional character.





The Taptap family consists of a chair and a stool, all made of solid ash and lacquered in colour.

Available in different colors options.



Jara

The Jara collection is born around a basic silhouette. This shape of the one-piece seat with the subtle shape of the petals of the Jara flower, gives the characteristic to the entire collection.



The silhouette of the seat generates subtle curves at the end of the seat and the backrest that give it a great aesthetic differentiation.



Nid

The name NID is derived from the French word for «nest» – an armchair and a sofa designed to create a friendly, cozy atmosphere, separating a person from the hustle and bustle, and helping to focus on a conversation or work. Its closed, rounded shapes protect you from the outside world while encouraging communication within.



The collection is available in a variety of fabrics and colors.



Tuttu Monteur



The Tuttu Monteur collection takes its name from the French word for "editor." Inspired by the concept of someone who carefully removes the unnecessary to leave only the best, designer Sergey Lvov created sofas and armchairs that embody this craft through their form.





Smooth shapes form a clean silhouette, which is particularly well for modern interiors.

Available in different colors and upholstery options.



Katana

The shapes and patterns in the Katana collection were inspired by traditional Japanese katana sword and kimono dress. These two unique seating options offer comfort and harmony with peaceful touch of Zen style to your space.





The collection is available in a variety of finishes and upholstery options to suit your style.

Beads



The main idea was to use a simple small form of craft wooden beads in furniture. The natural pattern of ashwood supplements these items and makes them friendly and ecological.



The modern Scandinavian design of these tables is well suitable for contemporary interiors of restaurants, offices as well as homes.





Beads table is available with different colors options and countertop dimensions.

Porto

The Porto side table was developed by designer Pavel Vetrov and the Artu design bureau. The visual inspiration for the table came from the picturesque bridges of the Portuguese city, while the ergonomic aspects were calculated based on the characteristics of modern lifestyles.

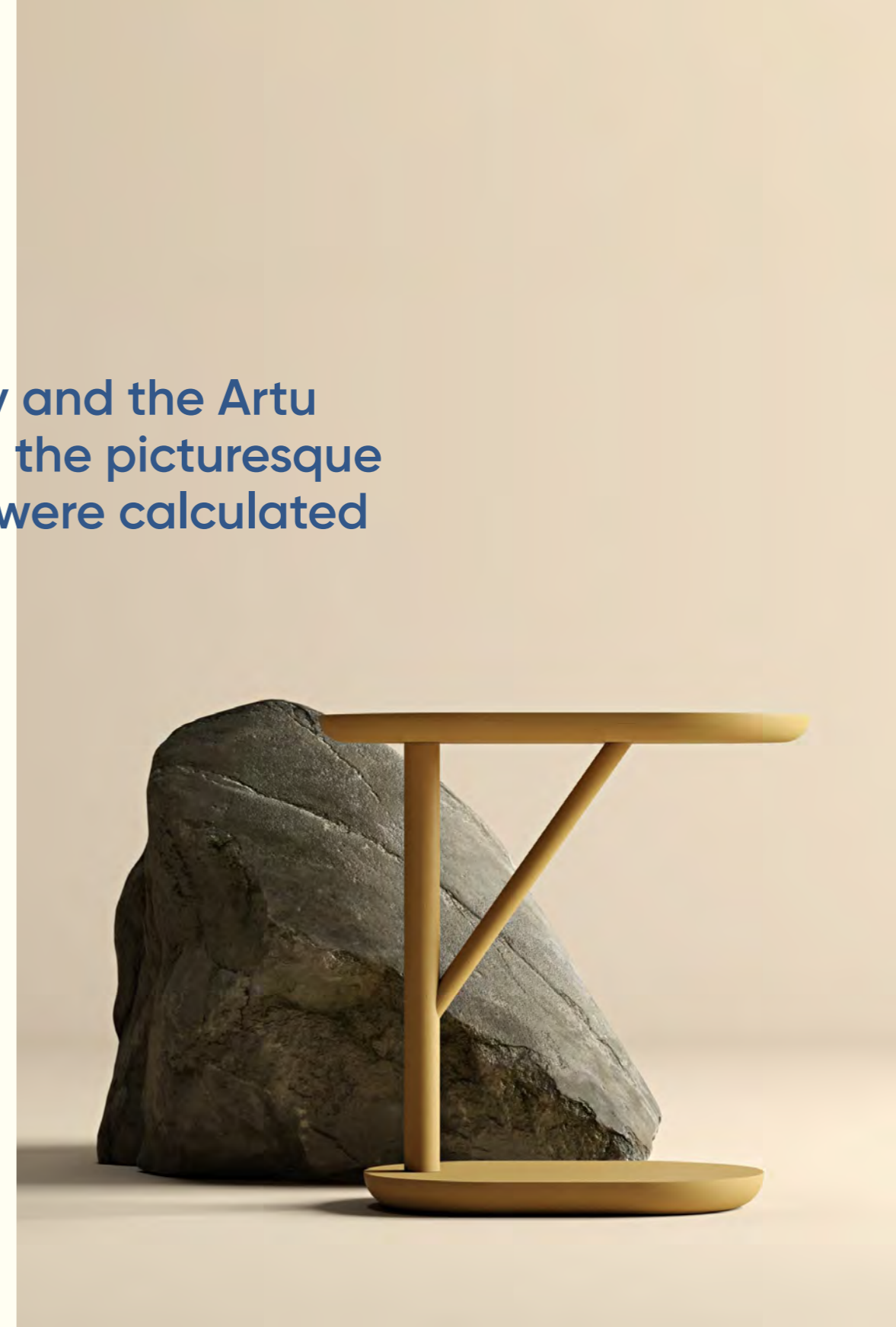



This table is specifically designed to be comfortable for computer use while sitting on a sofa or in a lounge chair.

Lasso

The Lasso coat stand offers a fresh perspective on the design and ergonomics of everyday items. Its large round component significantly increases the usable storage area while occupying almost the same amount of space as traditional hangers.



In addition to its functionality, the Lasso boasts an original shape, making it a perfect addition to modern minimalist interiors.

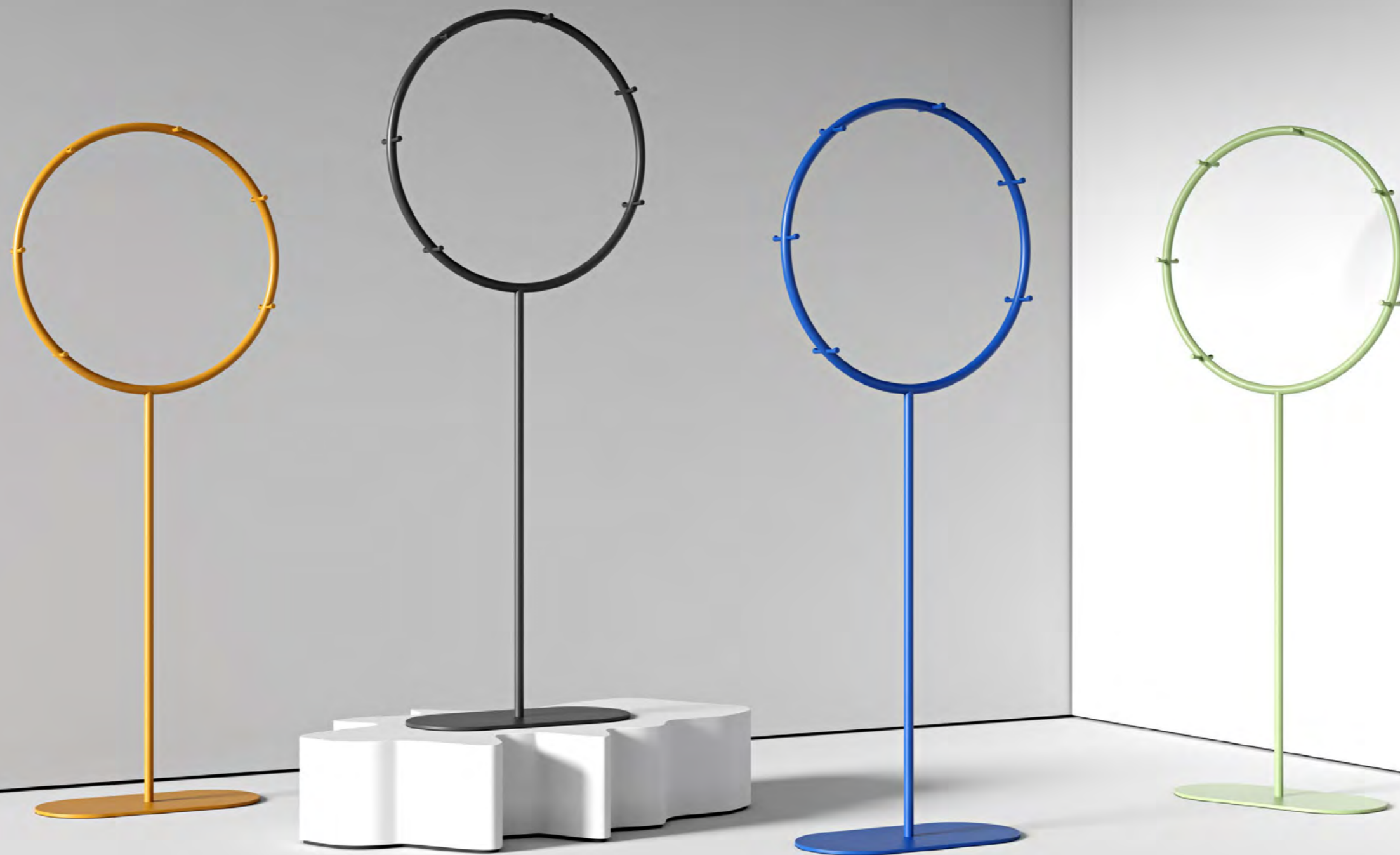

Cesto



Cesto means a basket case in Spanish. The inspiration for the Cesto collection comes from the shape of this object, which is typical in many cultures and is used to collect or store other objects. They have a characteristic design and are usually made of rattan or other natural fibers.



The Cesto chair has a unique form. Its main feature is its complex appearance, with the simplicity of its construction.



Lymmy

Design studio Levantin took inspiration from the serene beauty of snowy landscapes to create this chair. The design features monolithic, tactile elements that subtly evoke the warmth and tranquility of a peaceful northern scene, offering a sense of infinite harmony. The chair, named Lymmy, showcases appealing slanted proportions, supported by three broad legs.



This armchair can be produced with any upholstery according to customer wishes.



LeTube



Figuron Design Studio created the LeTube collection specifically for Artu. This collection of metal seating is designed for outdoor use with the sophistication of indoor furniture.



LeTube chairs are perfect for street cafes and terraces, but they can also be used in living areas for an added touch of color.



The LeTube collection includes a classic metal frame chair, a bar stool, and a bar stool with a back.



Marco



Collection is suitable for different styles of interior due to its minimalistic design and well thought out ergonomics. The chairs base and legs are made of solid beech. Seat and backrest are based on metallic frame with a soft upholstery. The model is available in various ways.



Items from the Marco collection are available for order in various upholstery and paint finishes.



Marco Pleat

Marco Pleat is a new version of Marco armchairs that were designed by Figuron. We freed the forms and it became a little bit more cozy and surreal.



These chairs are available with 2 different bases & in any color.



Marco Metal



Marco metal is a continuation of the collection of chairs and armchairs designed by Figuron. Laconic design and well-thought-out ergonomics make Marco Metal versatile for interiors of different styles.





The frames of Marco metal chairs and armchairs are made of bent metal pipes. Each model can be equipped with one of two types of bases L1 and L2.

Marco office

Marco office chairs are an extension of the FIGURON studio collection. While preserving key features such as ergonomics and a versatile design, they are specifically crafted for both office spaces and home offices.



Office chairs can be equipped with two different bases.



Available in any upholstery based on customer requests.



TECH SPEC

model • dimensions • materials

WOX

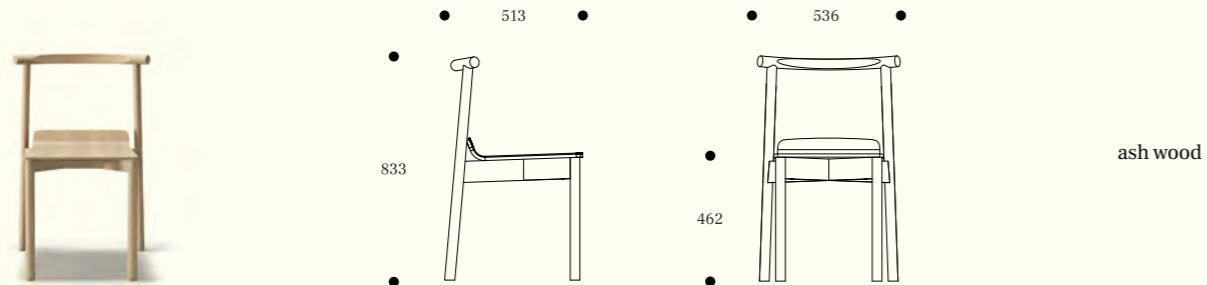

WOX S

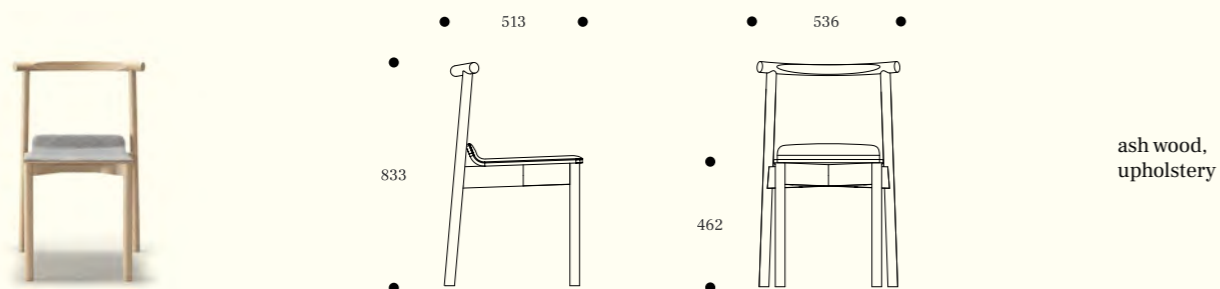

WOX 2

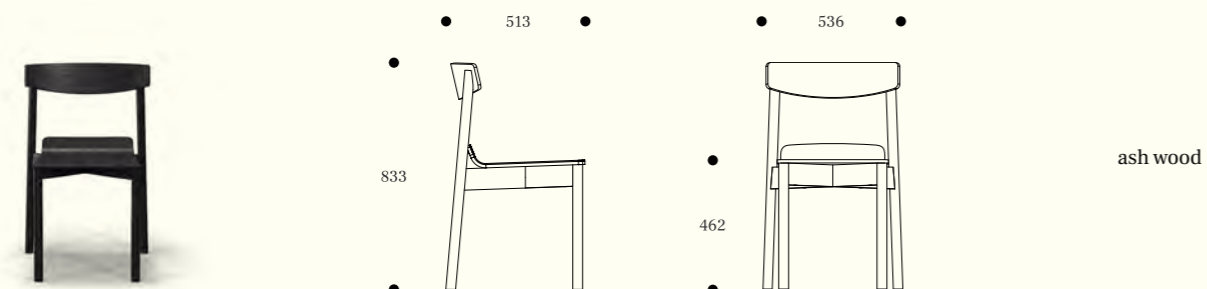

WOX 2S

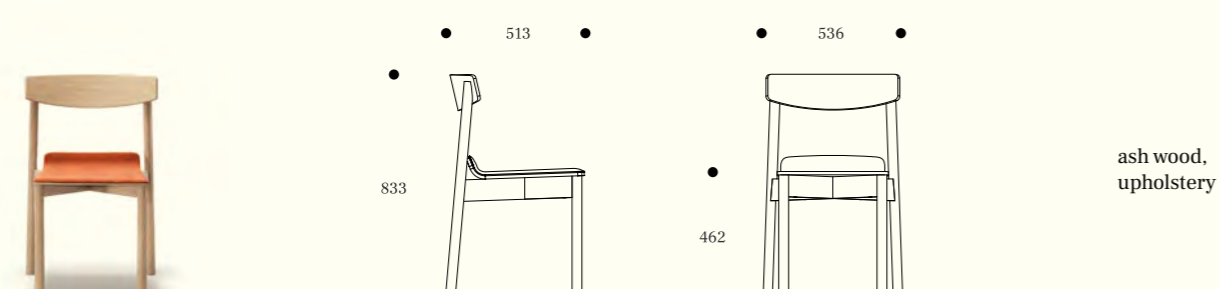

for more details, 3D models, etc visit our website

TECH SPEC

model • dimensions • materials

WOX FLAT

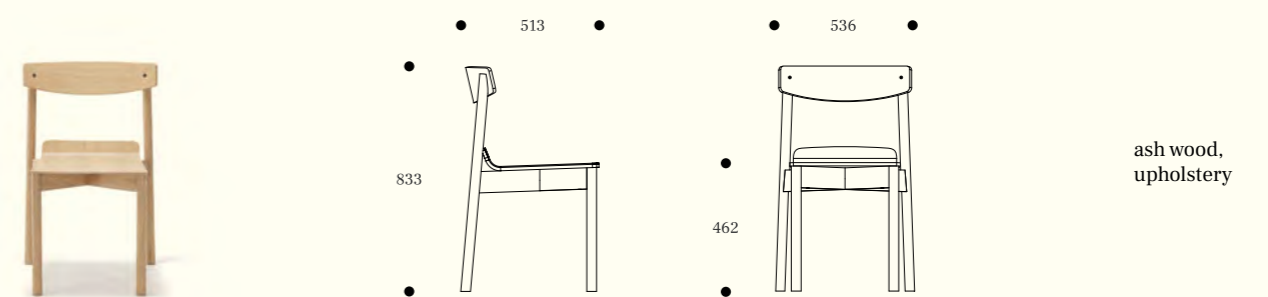

WOX BAR

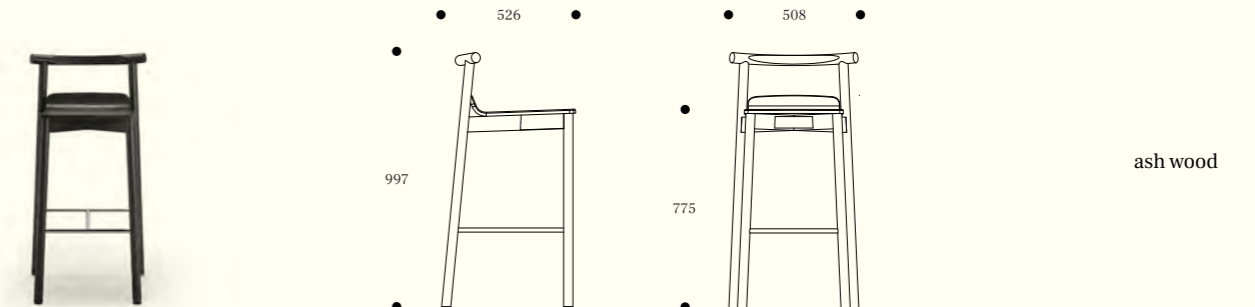

WOX BAR S

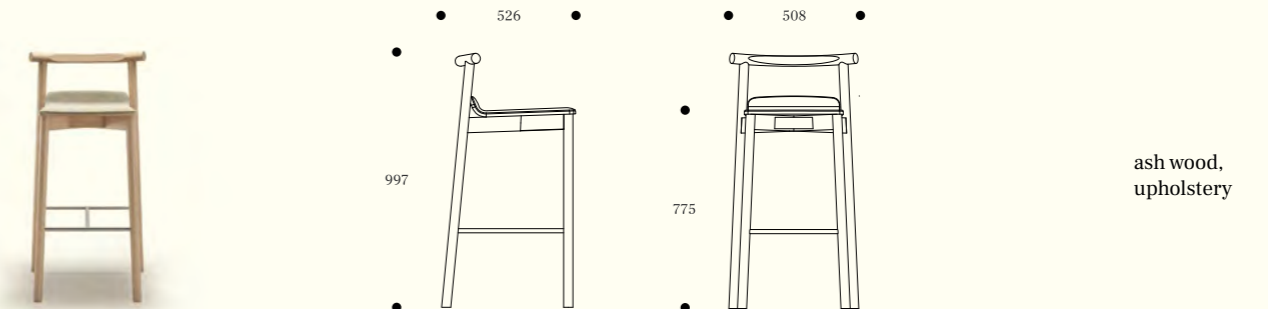

for more details, 3D models, etc visit our website

TECH SPEC

model • dimensions • materials

MOSS 1300

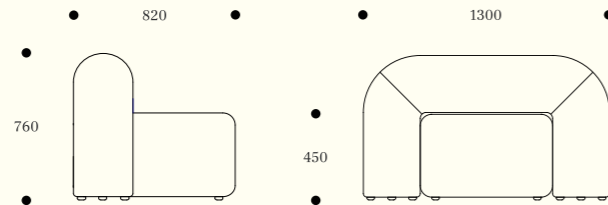

upholstery
wooden frame

MOSS 1300

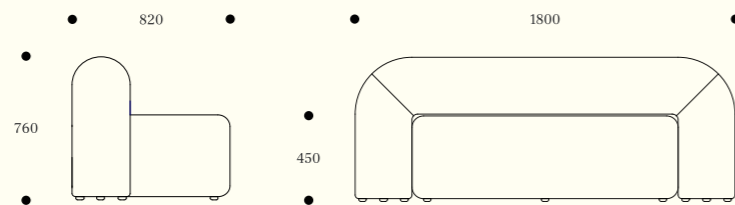

upholstery
wooden frame

MOSS 1300

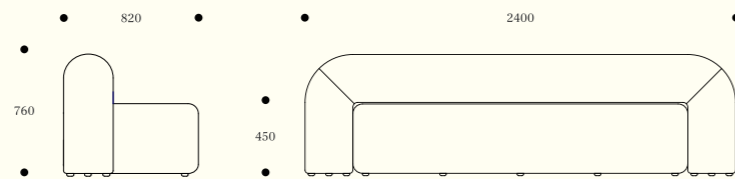
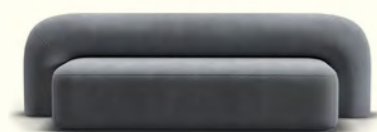

upholstery
wooden frame

EDDIE

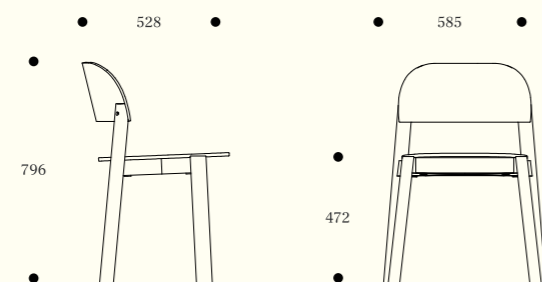

beech
veneered plywood

for more details, 3D models, etc visit our website

TECH SPEC

model • dimensions • materials

EDDIE BAR

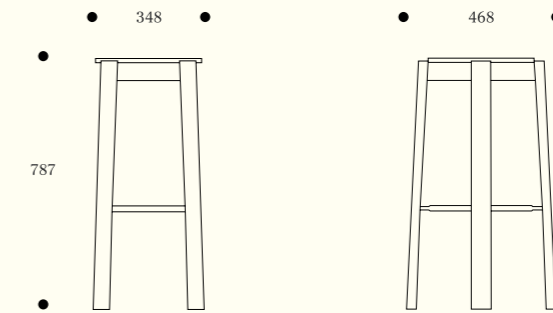

metal,
beech

EDDIE HALF BAR

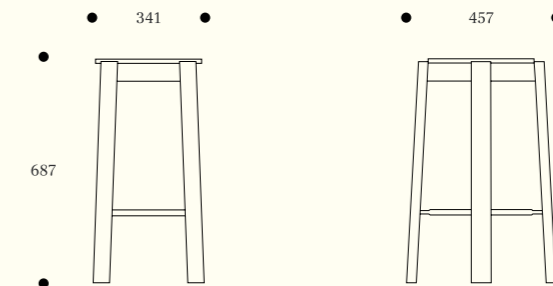

metal,
beech

LOVER

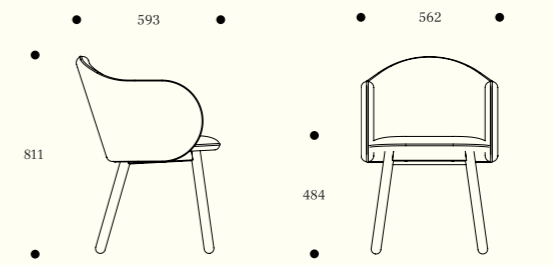

ashwood,
upholstery

LOVER BAR

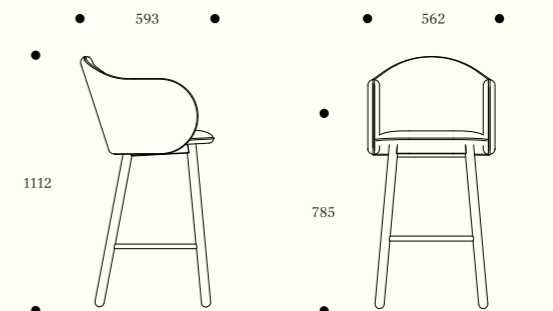

ashwood,
upholstery

for more details, 3D models, etc visit our website

TECH SPEC

model • dimensions • materials

LOVER OFFICE

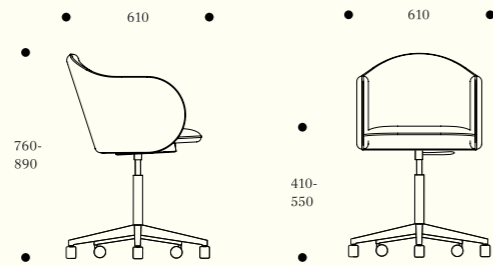

plastic,
metal
upholstery

LOVER OFFICE SWISS

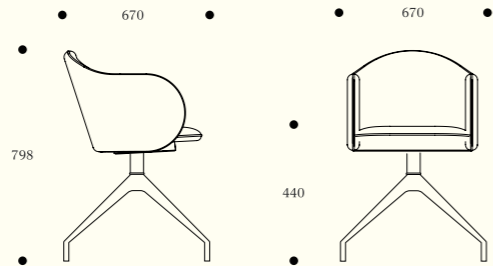

plastic,
metal
upholstery

LOVER SOFA

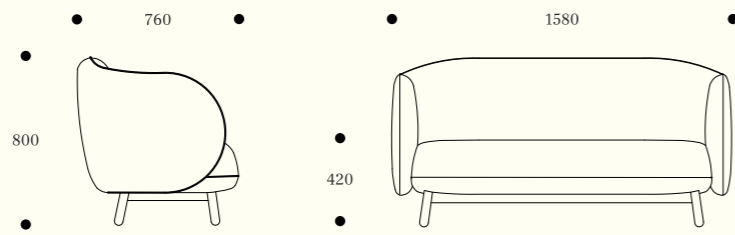

ashwood
upholstery
wooden frame

LOVER ARMCHAIR

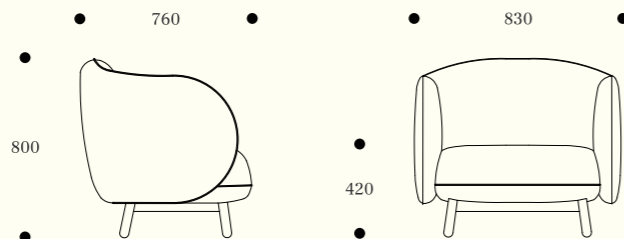

ashwood
upholstery
wooden frame

for more details, 3D models, etc visit our website

TECH SPEC

model • dimensions • materials

TAP TAP

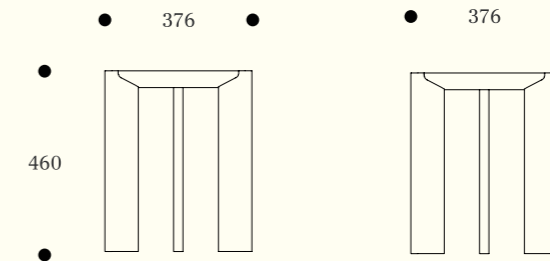

ashwood

TAP TAP ARMCHAIR

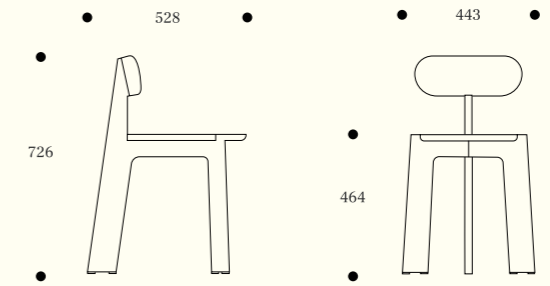

ashwood

JARA

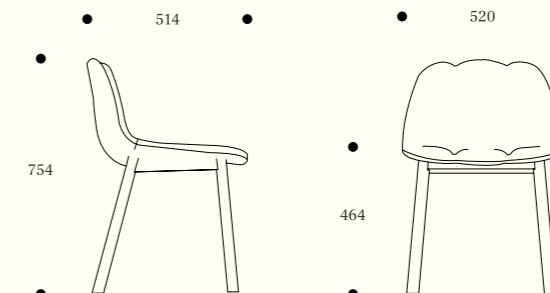

ashwood,
upholstery

for more details, 3D models, etc visit our website

TECH SPEC

model • dimensions • materials

NID SOFA 1

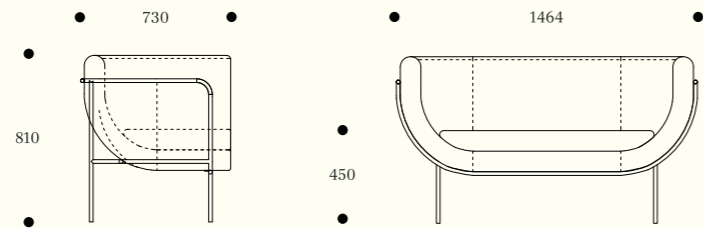

metal
upholstery

NID ARMCHAIR 1

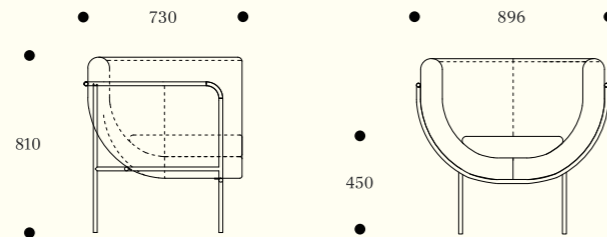

metal
upholstery

TUTU SOFA

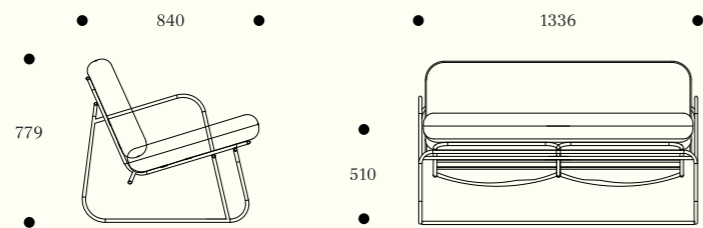

metal
upholstery

TUTU ARMCHAIR

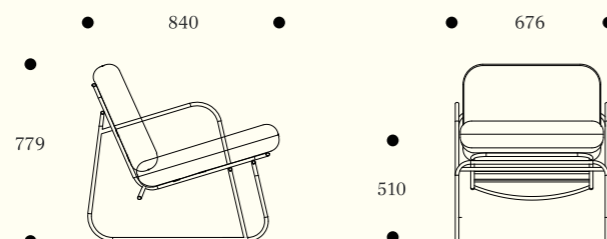

metal
upholstery

for more details, 3D models, etc visit our website

TECH SPEC

model • dimensions • materials

KATANA CHAIR

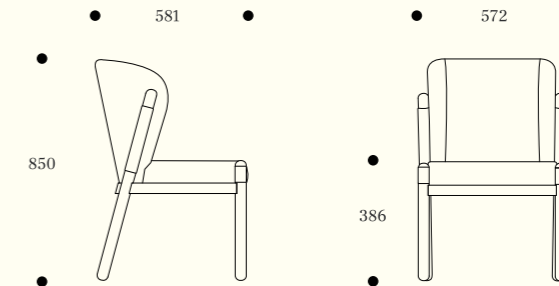

metal,
ashwood,
upholstery

KATANA LOUNGE CHAIR

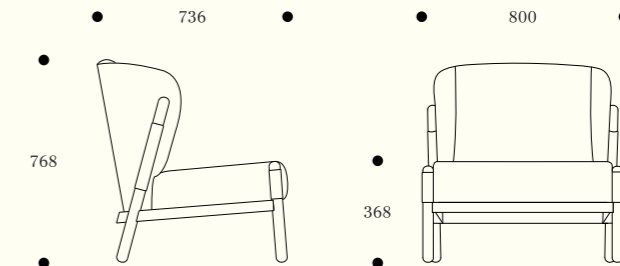

metal,
ashwood,
upholstery

BEADS

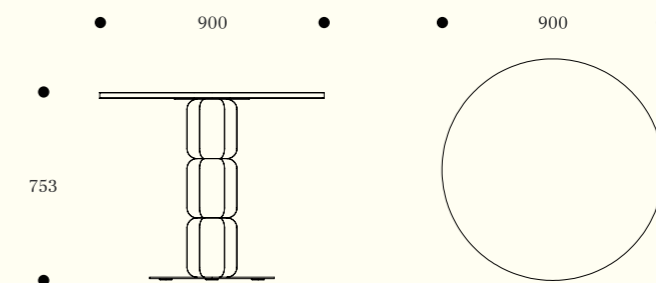

metal,
ashwood

BEADS COFFEE TABLE

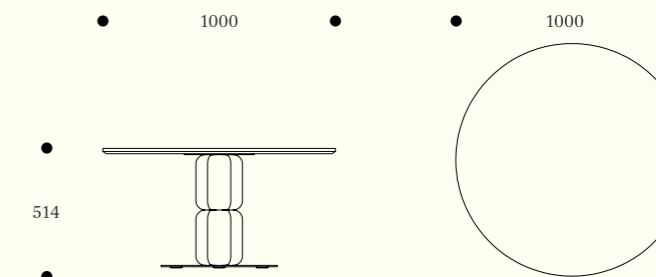

metal,
ashwood

for more details, 3D models, etc visit our website

TECH SPEC

model • dimensions • materials

PORTO ROUND

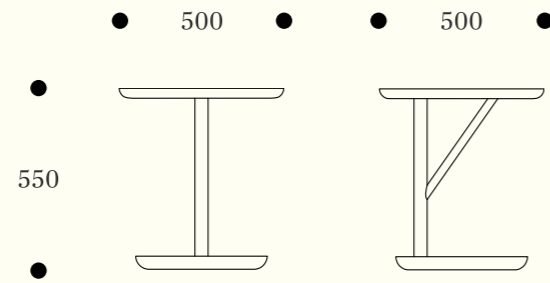

ashwood

PORTO OVAL

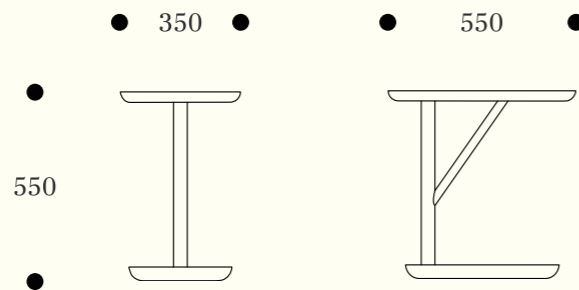

ashwood

LASSO

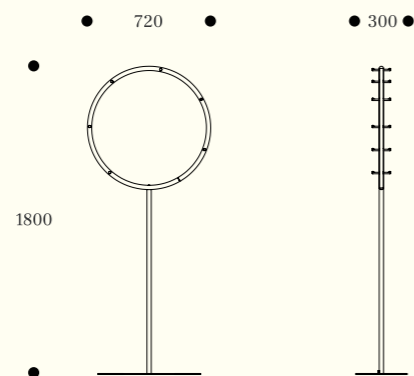

metal

CESTO

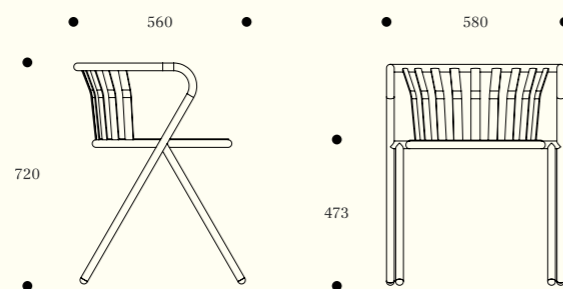

metal

for more details, 3D models, etc visit our website

TECH SPEC

model • dimensions • materials

LYMMY

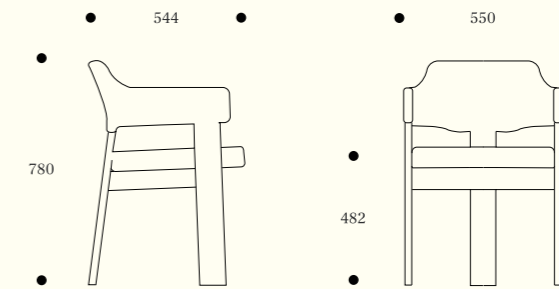

ashwood
upholstery

LETUBE

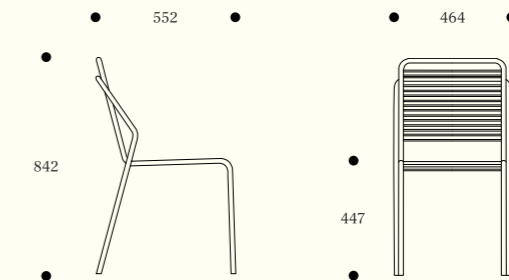

metal

LETUBE BAR

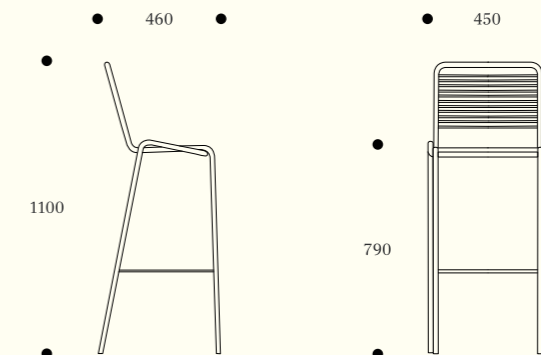

metal

MARCO M1

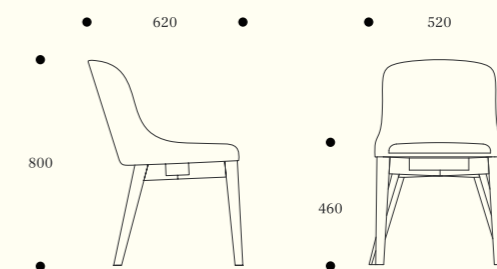

metal,
beech,
upholstery

for more details, 3D models, etc visit our website

TECH SPEC

model • dimensions • materials

MARCO M2

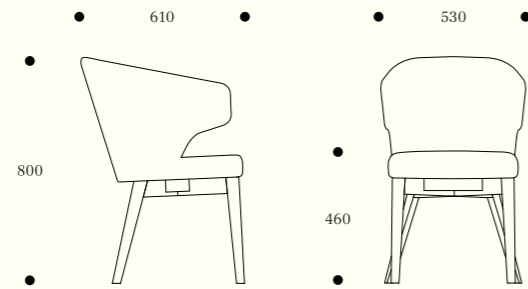

metal,
beech,
upholstery

MARCO M3

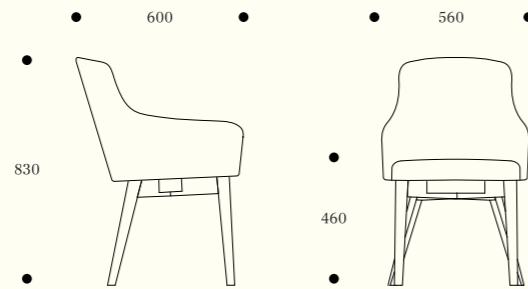

metal,
beech,
upholstery

MARCO PLEAT L1

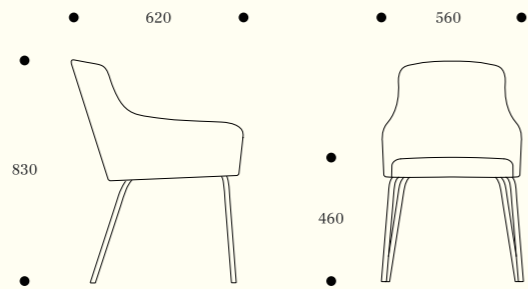

metal,
upholstery

MARCO PLEAT L2

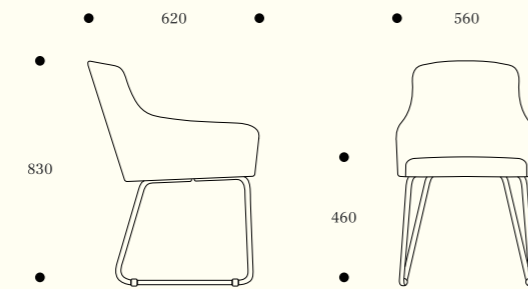

metal,
upholstery

for more details, 3D models, etc visit our website

TECH SPEC

model • dimensions • materials

MARCO L1

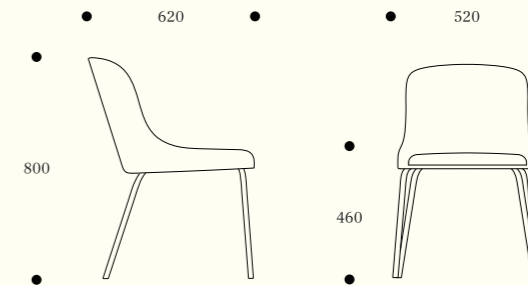

metal
upholstery

MARCO L2

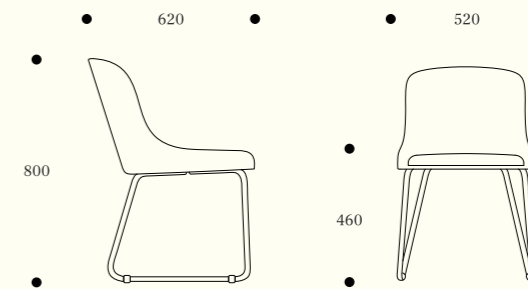

metal
upholstery

MARCO M2 L1

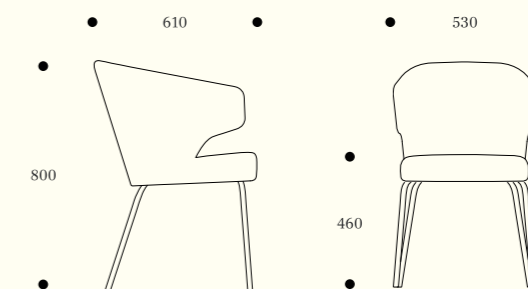

metal
upholstery

MARCO M2 L2

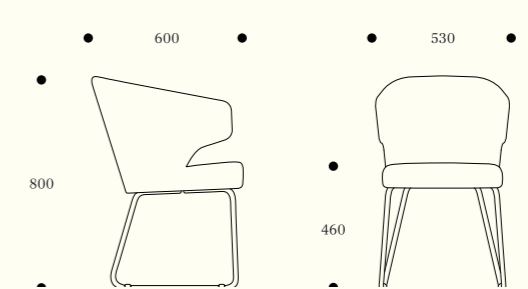

metal,
upholstery

for more details, 3D models, etc visit our website

TECH SPEC

model • dimensions • materials

MARCO M3 L1

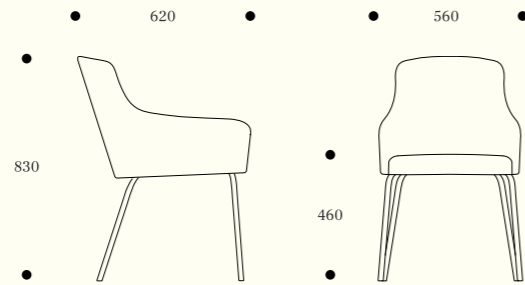

metal,
upholstery

MARCO M3 L2

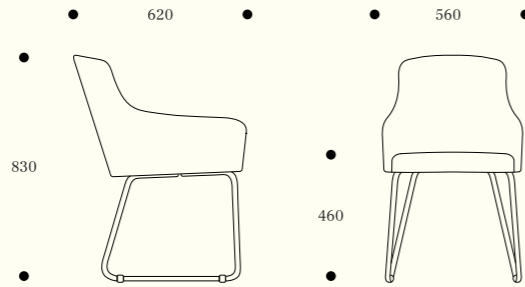

metal,
upholstery

MARCO OFFICE

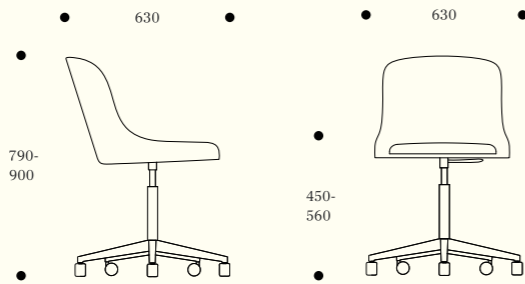

metal,
upholstery

MARCO OFFICE SWISS

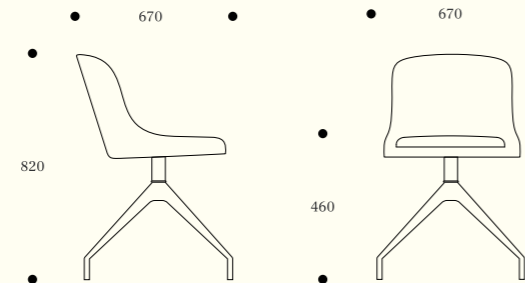

metal,
plastic,
upholstery

for more details, 3D models, etc visit our website

TECH SPEC

model • dimensions • materials

MARCO M2 OFFICE

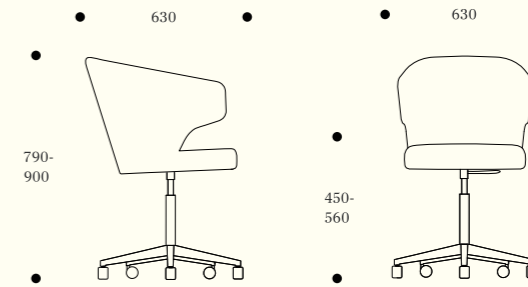

metal,
upholstery

MARCO M2 OFFICE SWISS

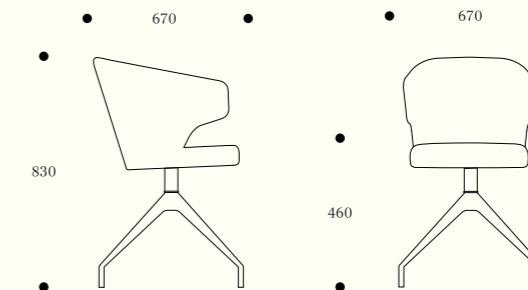

metal,
plastic,
upholstery

MARCO M3 OFFICE

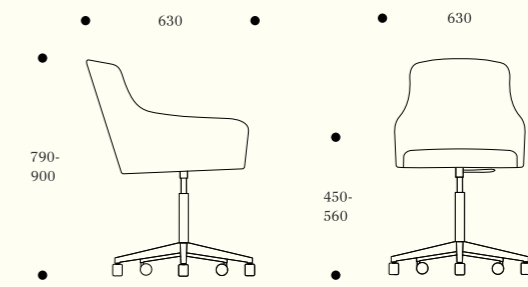

metal,
upholstery

MARCO M3 OFFICE SWISS

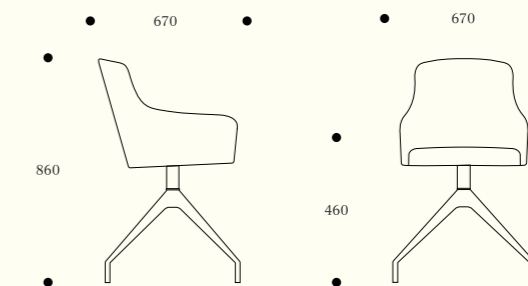

metal,
plastic,
upholstery

for more details, 3D models, etc visit our website



STUDIO MORITZ PUTZIER is a multifaceted design studio headquartered in Cologne that offers a wide range of design services, including furniture, lighting, and user-oriented product and interior design concepts.

With a strong emphasis on practical solutions to everyday problems, the studio is best known for its innovative approach to furniture and lighting design.



Moritz's design philosophy is characterized by a harmonious blend of clean lines and natural materials, often incorporating subtle technical details. In the words of the designer himself, his work possesses "with a little twist"—a subtle and understated aesthetic that adds a touch of whimsy to even the most practical of designs.

Ukrainian designer specialized in furniture and interior design with almost a decade of professional experience, including commissioned projects from famous brands such as Lexus, Temahome, TwoSix, Zegen and many more.

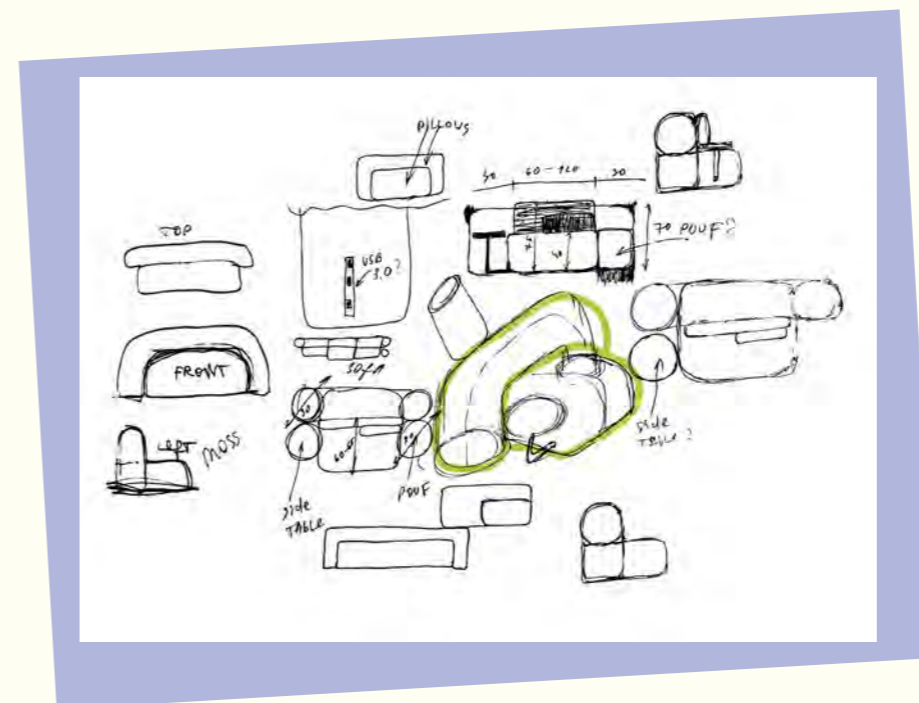

Among 70 awards in design he has amassed throughout his career is the Red Dot Award, German Design Award.

His work has been shown, mentioned and analyzed in the most important magazines around the world, including Forbes, Elle, Vogue, Le Figaro, among others, and he is an assiduous participant of all European design shows, namely Imm Cologne, Salone del Mobile Milano, London Design Fair and Paris Design Week.

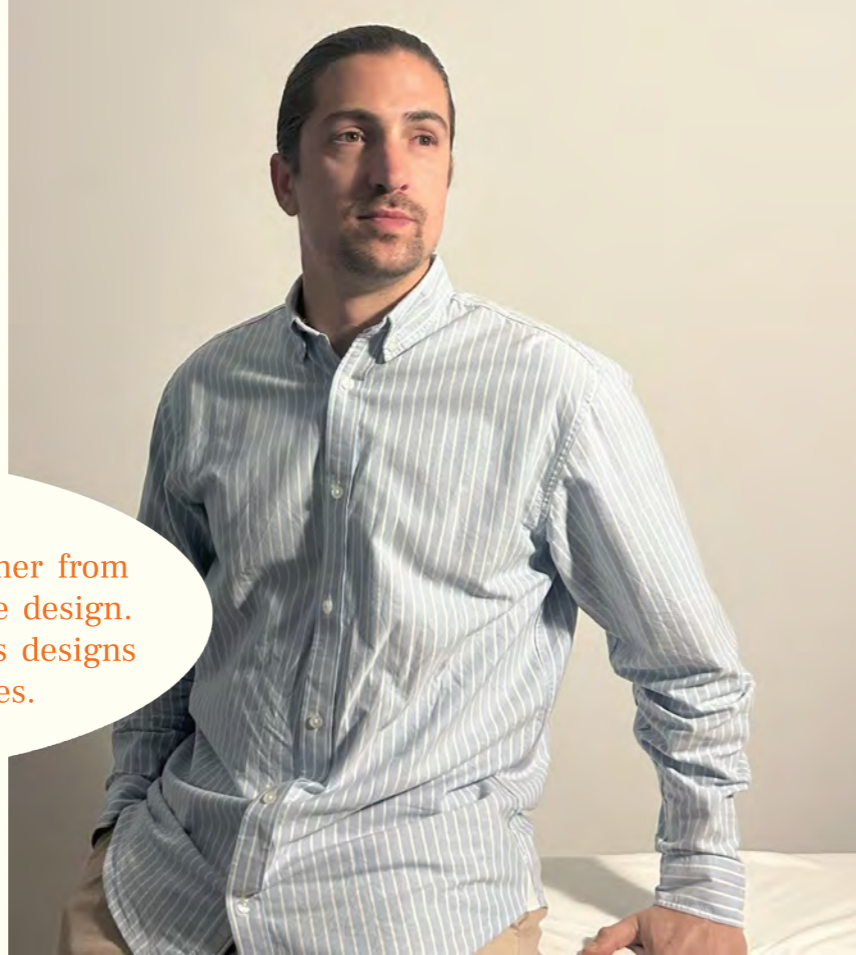

Pablo is a product designer from Valencia (Spain), specialized in furniture design. His roots in this coastal city provide his designs expressive, colorful and cheerful attributes.



He is passionate about Mediterranean culture. His vision of design lies in the connection generated between the product and the user, creating friendly and human designs.



Levantin Design is a multidisciplinary studio founded by brothers Sergey and Alexander Lvov. They began in 2012 with bold experiments in furniture refurbishment, which quickly led to the launch of their own industrial designs.

Their approach to design can be described as "WOW in your space", implementing bold and cosmopolitan ideas that appeal to those with a creative outlook on the world.

Levantin Design's products have been exhibited at French Design Week in Paris and at furniture exhibitions in Ukraine, Poland, and Azerbaijan. Their work has been featured in numerous international trade journals, including Architectural Digest, Elle Decoration, Hospitality Design, Domus, Interni, Wired, Casa e Jardim, and Casa Claudia.

